

# INSTRUCCIONES DE ENSAMBLE

## ASSEMBLY INSTRUCTIONS



**\* Instrucciones de Instalación:** Mueble Barra GEOS 160 x 90 / mueble para cocina  
**\* Installation Instructions:** GEOS kitchen bar cabinet 63" x 35.4" / kitchen cabinet

### RECOMENDACIONES PREVIAS / Previous recommendations:



Si las paredes donde va a ubicar el mueble son en drywall, debe adquirir chazos y tornillos especiales para su instalación.

*If the walls where you are locating the cabinet are in drywall, you must purchase special ramplug and screws for installation.*



No golpee ni martille todo el mueble, sólo donde se le indica.

*Do not strike or hammer all the cabinet, only where directed.*



No pinte ni barnice el mueble.

*Do not paint or varnish the cabinet.*



No arrastre ni se suba al mueble, si necesita moverlo por favor levántelo.

*Do not drag or stand on the cabinet, if you need to move it please lift up.*



Lea detenidamente y siga en orden consecutivo las instrucciones de armado.

*Read carefully and follow in sequence the assembly instructions.*



No expongas el mueble a la intemperie, ni al calor.

*Do not expose the cabinet to the outdoors or the heat.*

### IMPORTANTE:

Antes de empezar a ensamblar el mueble, lea detenidamente las instrucciones. Pre-ensamble el mueble sobre su caja, para no rayarlos. Si falta una parte o piensa que esta defectuosa no devuelva el mueble al almacén; le agradecemos llamar al **(5-74) 444 17 71**, o comuníquese con su asesor principal, también nos pueden escribir a [servicioalcliente@firplak.com](mailto:servicioalcliente@firplak.com).

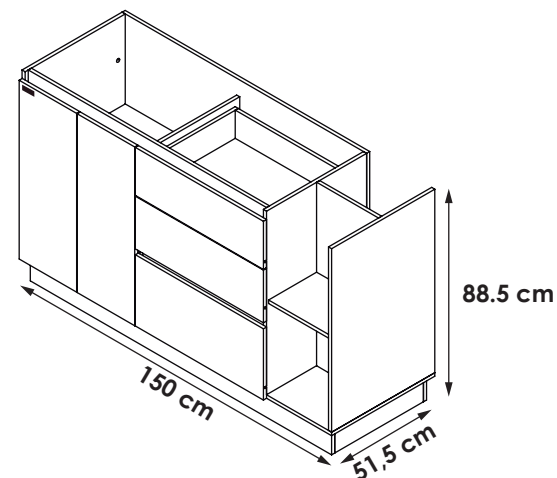

### Sello de calidad / Quality seal

**Por favor no deseche el instructivo del mueble, este le servirá para cualquier reclamo con respecto a la garantía del mismo.**

*Please do not discard the cabinet's instructions, it will serve you for any claim regarding its warranty.*

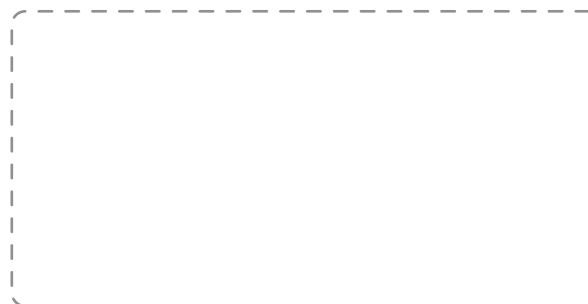

**IMPORTANT:** Before you start to assemble the cabinet, please read the instructions. Pre assembly the cabinet on its box, to prevent scratches. If a part is missing or damaged, do not return the furniture to the store, please call the **(5-74) 444 17 71** or contact your sales assistant. also you can write to [servicioalcliente@firplak.com](mailto:servicioalcliente@firplak.com).

# 1. Identificación de las partes

## Parts identification

HERRAMIENTAS REQUERIDAS / Tools required : \* No incluido. / Not included.

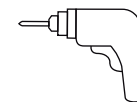
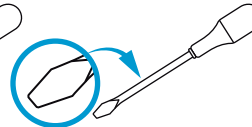
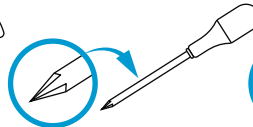
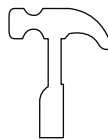
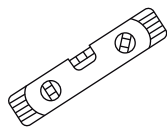
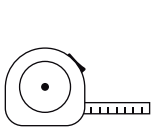

Taladro broca 5/16"  
5/16" Drill bit

### A Mueble para lavaplatos. Kitchen sink cabinet.



Tabla de piezas  
Parts Chart

Pieza / Part	Cantidad / Total
A	1
B	1
C	1
D	1
E	1
F	1
G	1
H	1
I	1
J	1
K	1
L	1
M	1
N	1
O	1
P	1
Q	1
R	1
S	1
T	1
U	1
V	1
W	1
X	1
Y	1
Z	1
AA	1
AB	1
AC	1
AD	1
AE	1
AF	1
AG	1
AH	1
AI	1
Cantidad Total	Desde From hasta to
35	A AI

### B Identificación de herrajes. Hardware identification

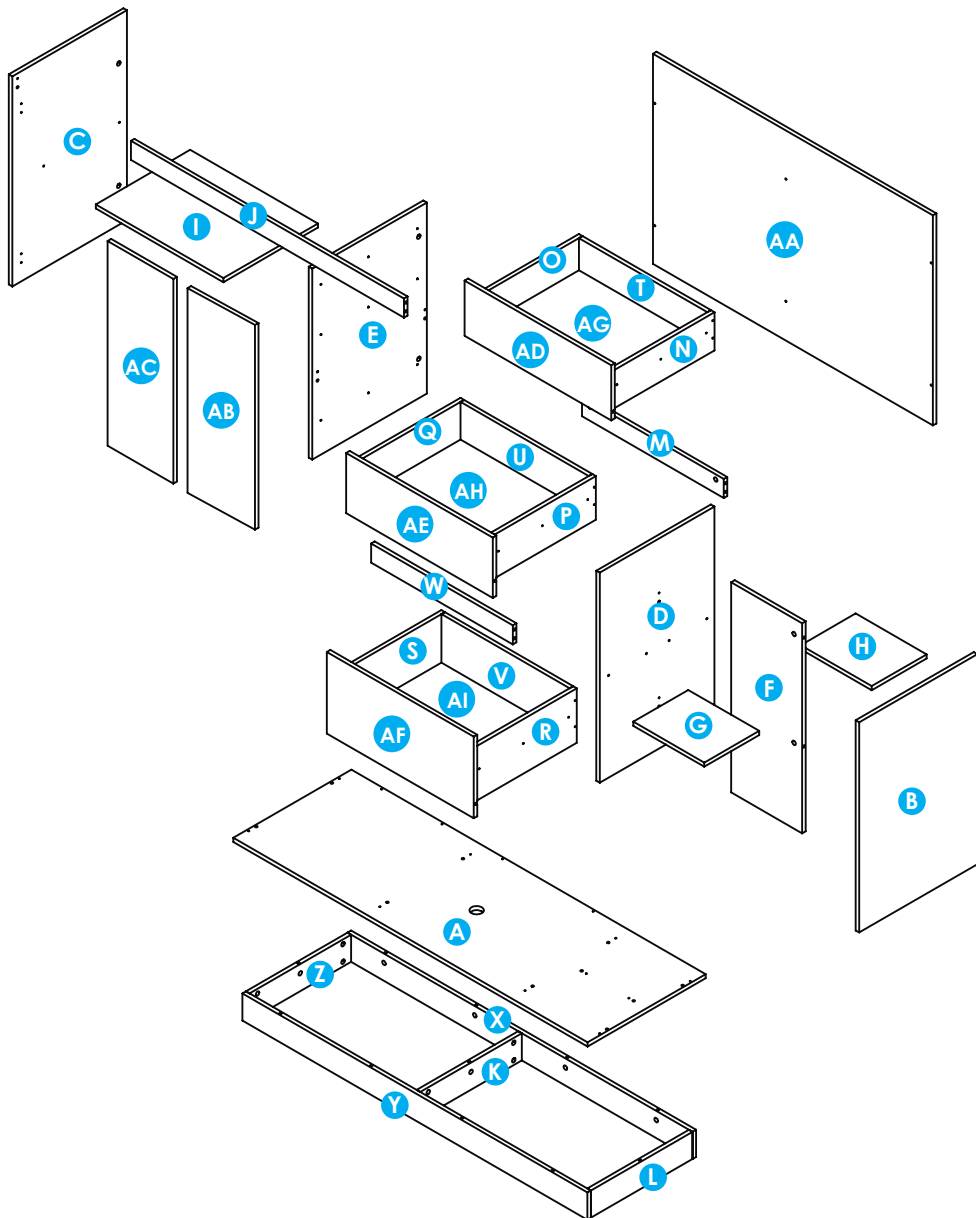

x49

Moneda Minifix  
Minifix cams



x49

Pernos Minifix  
Spreading bolt

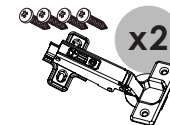

x2

Bisagras parche cierre lento  
Full soft close overlay hinges

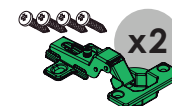

x2

Bisagras semi parche  
Half overlay hinges



x12

Soporte entepaño  
Shelf holder pins

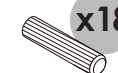

x18

Tarugos  
Wooden pins



x28

Tornillos ensamble 2"  
Assembly screws 2"



x6

Tornillos ensamble 1"  
Assembly screws 1"



x6

Riel full extensión  
cierre lento 450 mm  
Full extension slides  
slow closing 17.7"



x11

Deslizadores  
Sliders



x2

Ángulo metálico  
Steel angle bracket



x3

Chazos 2"  
Ramp plug 2"



x6

Tornillos 5/8  
5/8 screws



x3

Tornillos chazo 2"  
Ramp plug screws 2"

\* Tenga precaución al abrir la bolsa de herrajes de no perder ningún elemento. Compruebe si el contenido de las piezas es el correcto.

Be carefull opening the screw bag so you do not lose any. Chek if the number of screws is right.

## Instalación de minifix y pernos de minifix

Installing the minifix cams and spreading minifix

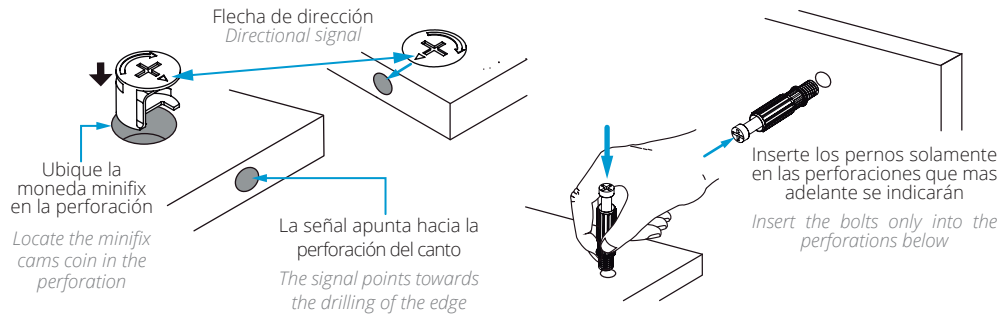

## Ajustes de partes

Parts adjustments

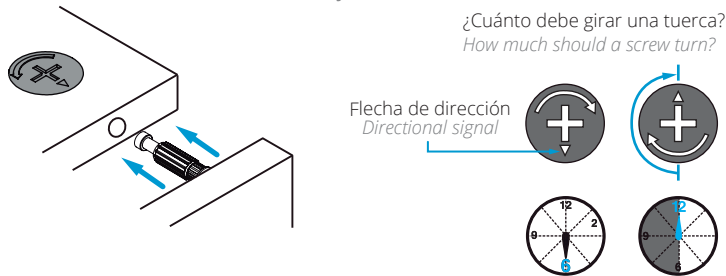

## Tarugos

Wooden pins

Introduzca los tarugos solo hasta su tope máximo  
Insert the wooden pins only up to their maximum peak

Inserte los tarugos solamente en las perforaciones que más adelante se indicarán  
Insert the wooden pins only into the perforations below

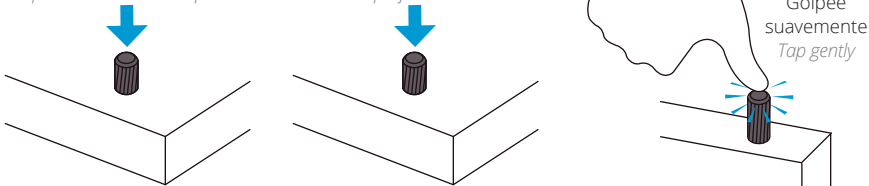

## 2. Preparación de las partes

Preparation of the parts

Se recomienda preparar las partes del mueble sobre la caja o una superficie lisa para no rayarlo.

It is recommended to prepare the parts of the cabinet on the box or on a flat surface to not scratch it.

Para este paso necesitarás:

For this step you will need:

### Herramientas

Tools



### Herrajes

Fittings



### IMPORTANTE:

Antes de iniciar el pre ensamble, separar el riel cuidadosamente, que consta de dos partes (1 y 2). Para separar, presione la palanca hacia abajo como indica la imagen 1.

### IMPORTANT:

Before starting the pre assembly, separate the slides carefully, the slides are made of two parts (1 and 2). To separate them, press the lever down as shown in image 1

### Imagen 1

Image 1

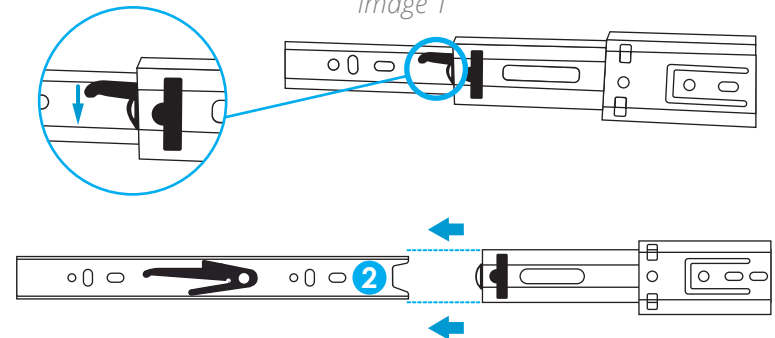

**NOTA:** asegure el riel donde coinciden las 3 perforaciones del riel con las 3 marcaciones sobre el muebles.

**NOTE:** Fix the slide where the 3 holes on the slide match the 3 screw marks on the cabinet.

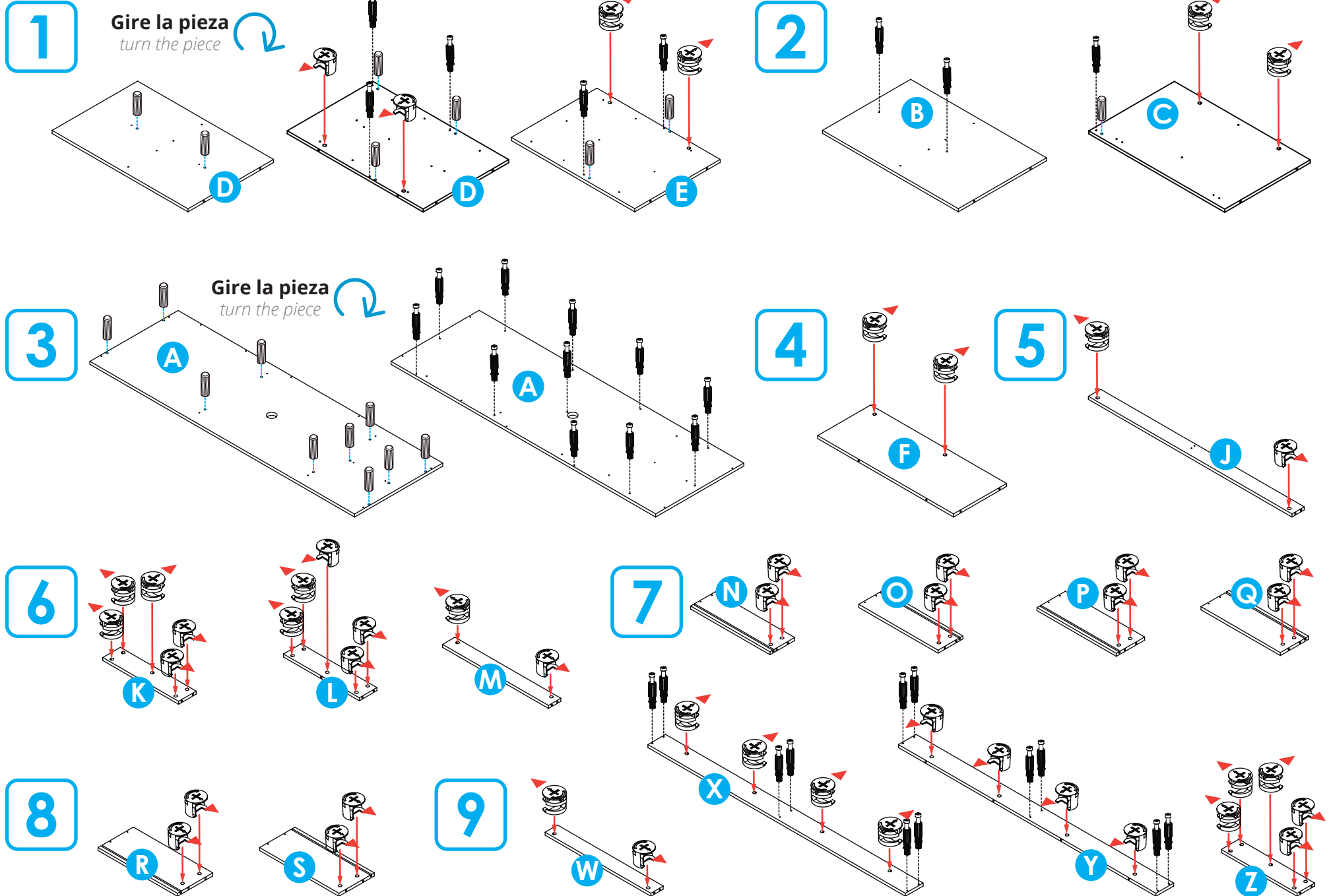

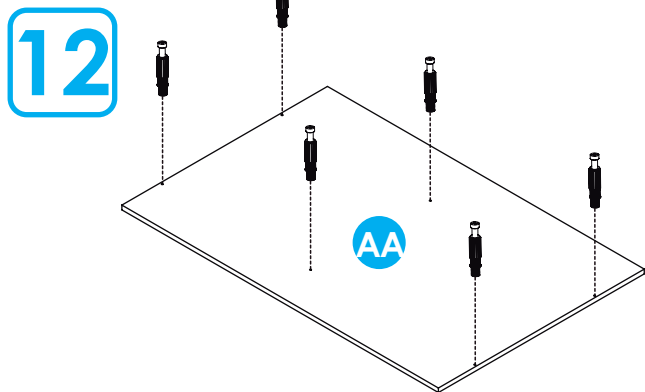
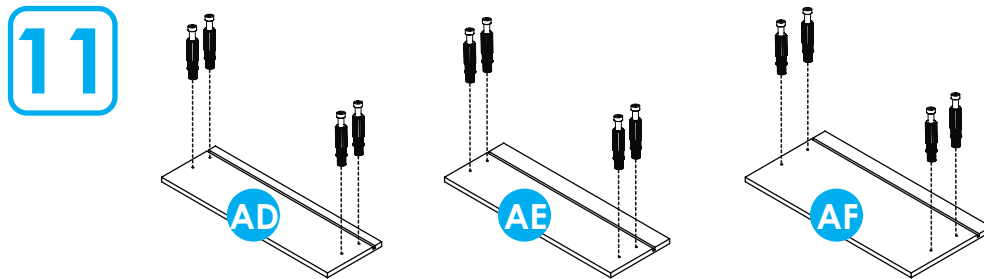
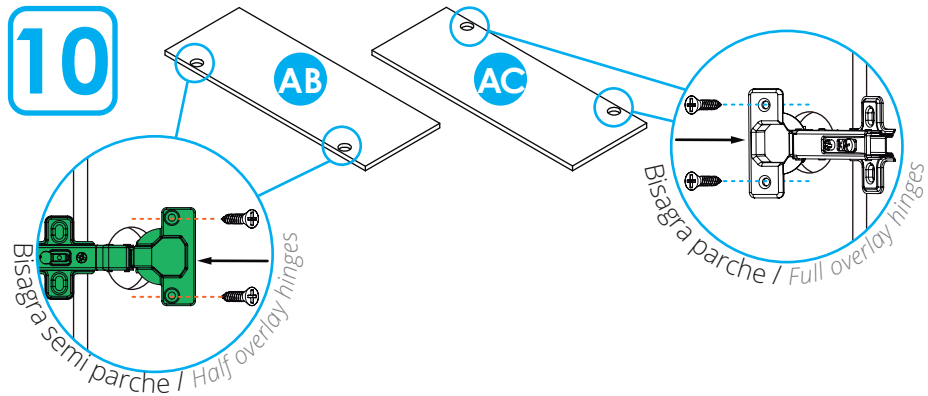

### 3. Preparación para ensamblar

#### Assembly steps

\* Se recomienda armar el mueble sobre la caja o una superficie lisa para no rayarlo.

*Is recommended to assemble the product top of the box or on a flat surface to not scratch it.*

Para este paso necesitarás:

*For this step you will need:*

#### Herramientas

*Tools*



Destornillador de estrella  
*Star screwdriver*

#### Herrajes

*Hardware*



Tornillos ensamble 2"  
*Assembly screws 2"*

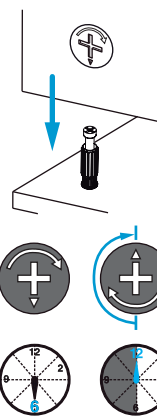

#### IMPORTANTE:

A medida que vaya encajando las piezas, ajuste con el destornillador.

#### IMPORTANT:

as the pieces fit together, adjust with the screwdriver.

#### IMPORTANTE:

De un correcto armado de los muebles depende su buen funcionamiento.

#### IMPORTANT:

A proper assembly of the furniture guarantees the performance of the hinges.

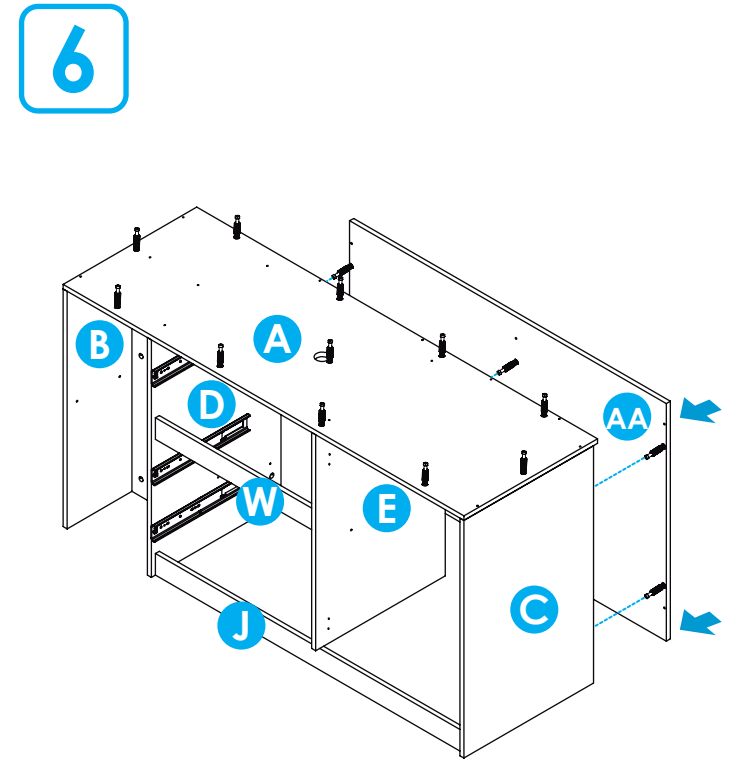
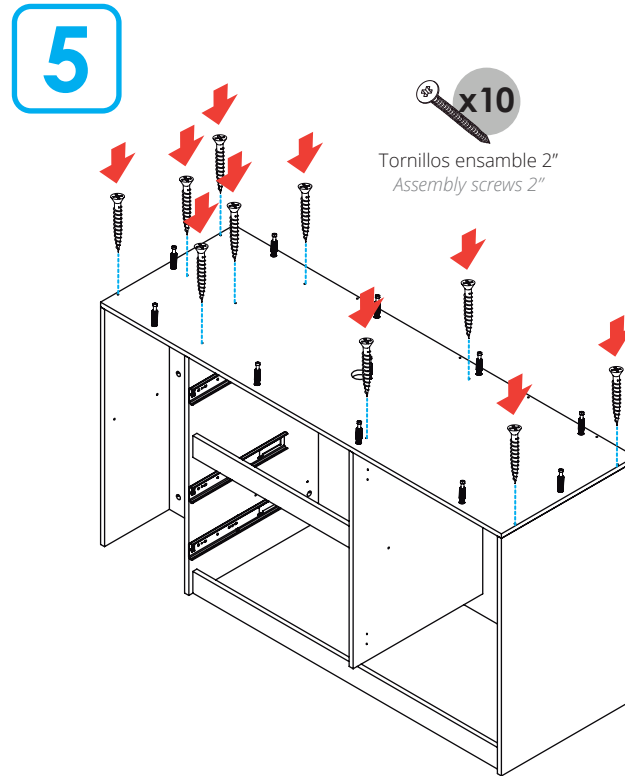
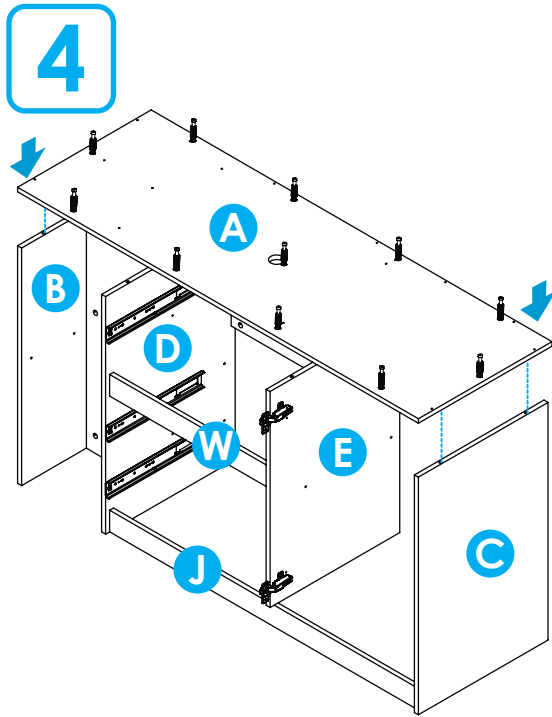
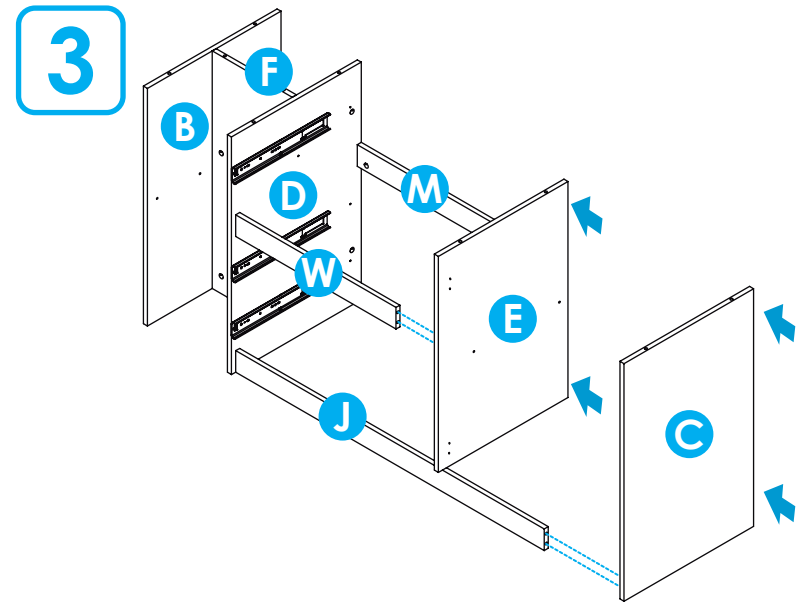
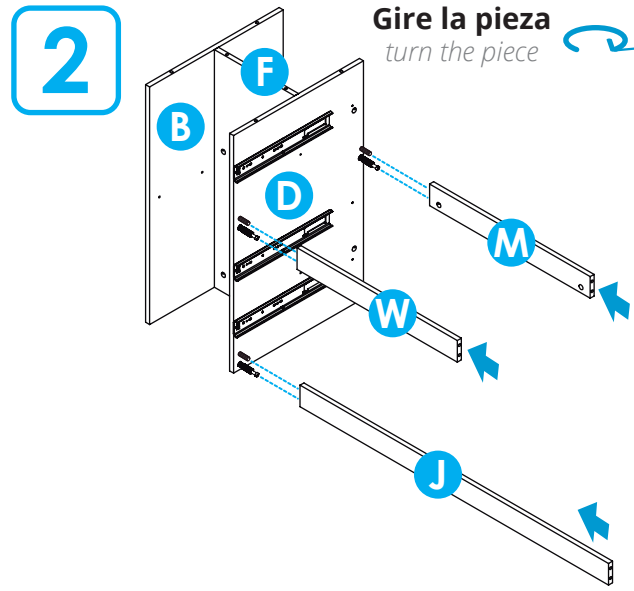
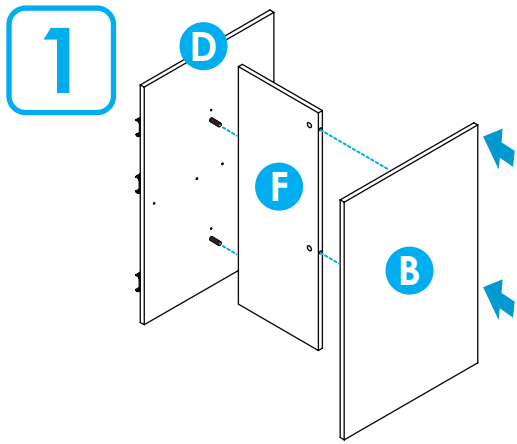

**IMPORTANTE:**

De un correcto armado de los muebles depende su buen funcionamiento.

**IMPORTANT:**

A proper assembly of the furniture guarantees the performance of the hinges.

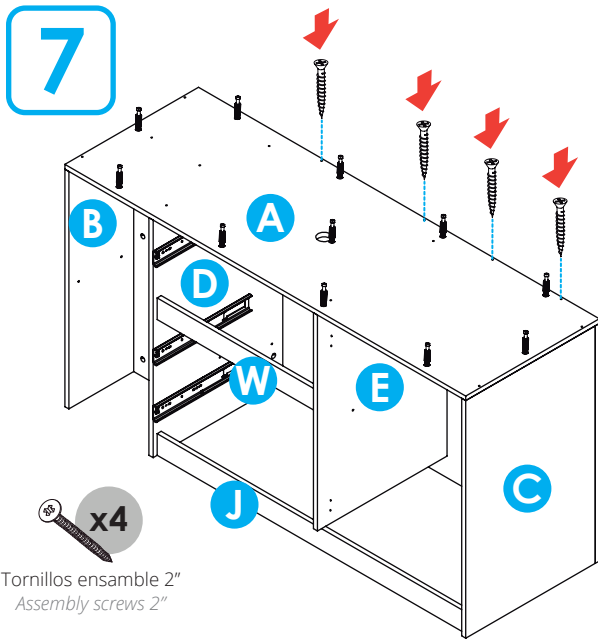

**x4**  
Tornillos ensamble 2"  
Assembly screws 2"

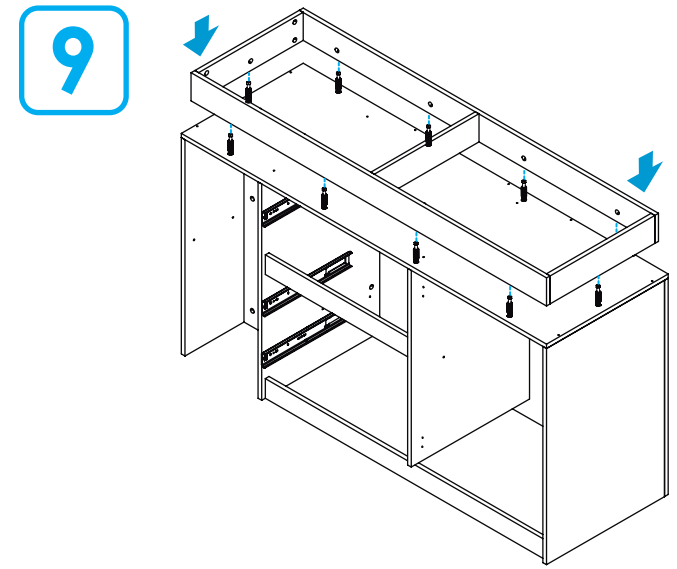
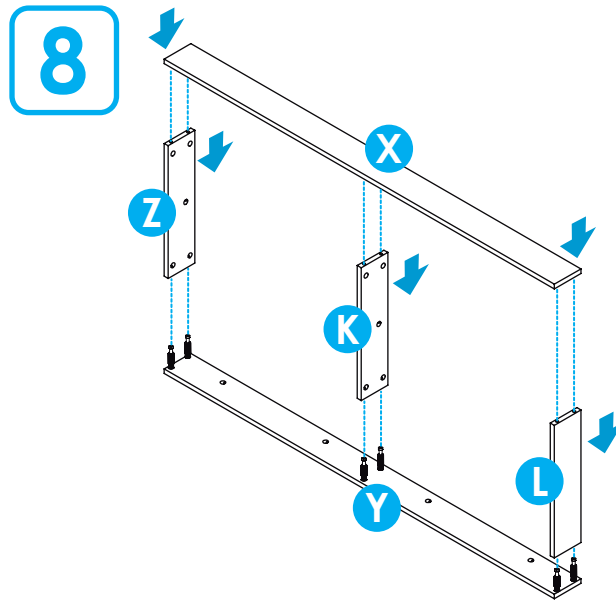

**10** Instale los deslizadores a 3 cm de las esquinas para dentro en la parte inferior del mueble con ayuda del martillo  
Install the sliders 3 cm from the inside corners in the part bottom of the cabinet using the hammer.

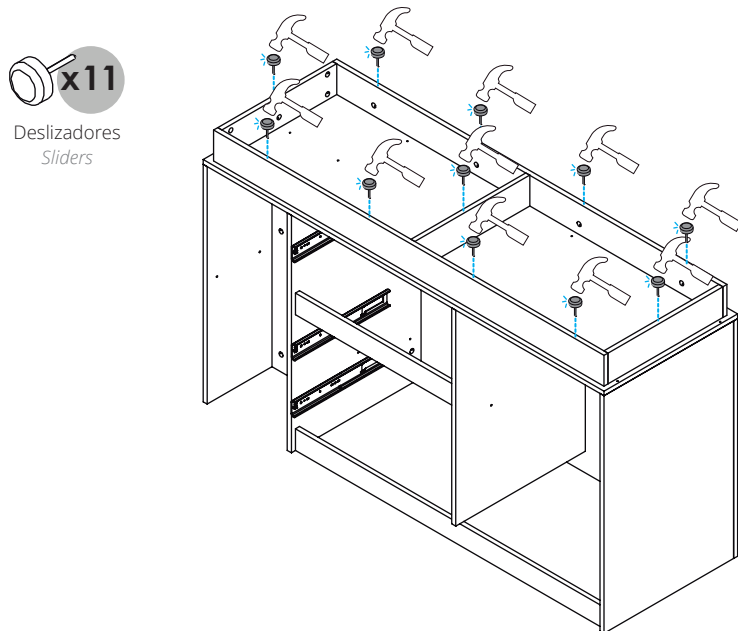

**x11**  
Deslizadores  
Sliders

**11** Instalación ángulo metálico.  
Installation of steel angle bracket

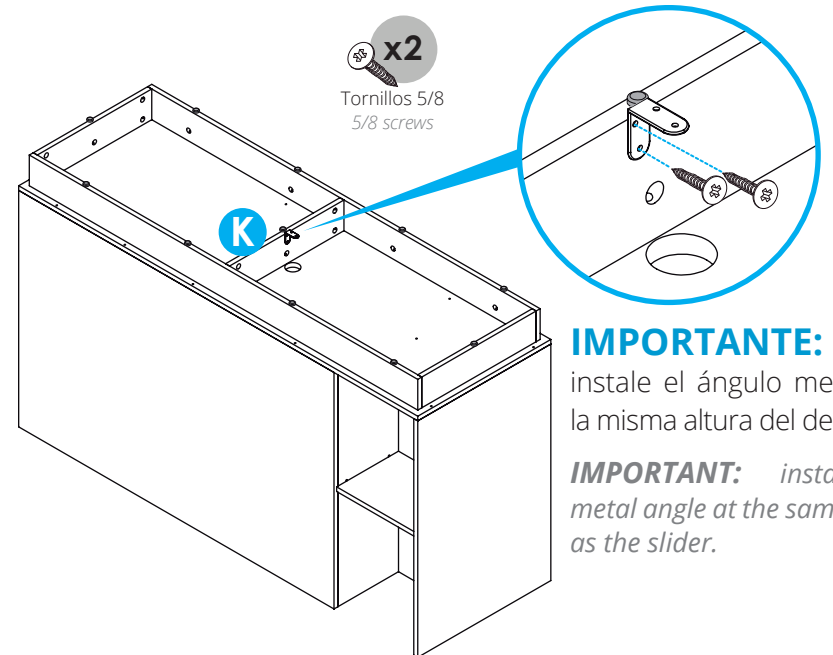

**x2**  
Tornillos 5/8  
5/8 screws

**IMPORTANTE:**  
instale el ángulo metálico a la misma altura del deslizador.  
**IMPORTANT:** install the metal angle at the same height as the slider.

**12** Armado de cajón superior.  
Upper drawer assembly

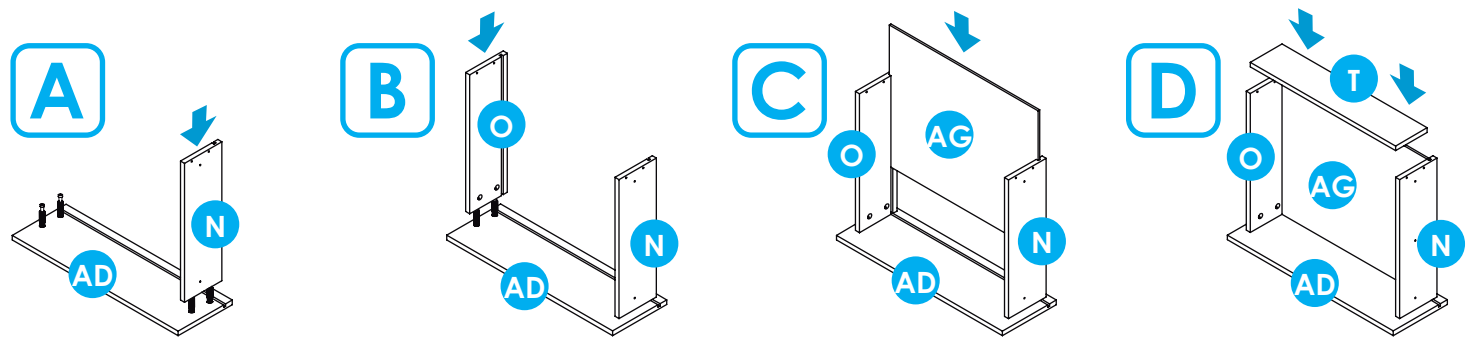

**E** **NOTA:** El riel parte 2 se fija en los laterales del cajón L y M.  
*Note: Slide part 2 is assembled on the sides of part L and M.*

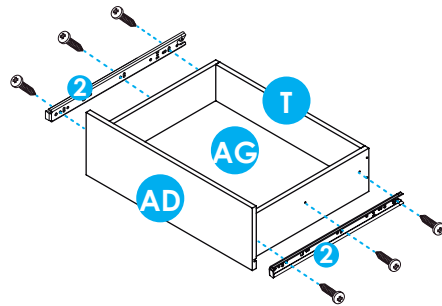

**F** **x4**  
Tornillos ensamble 2"  
Assembly screws 2"

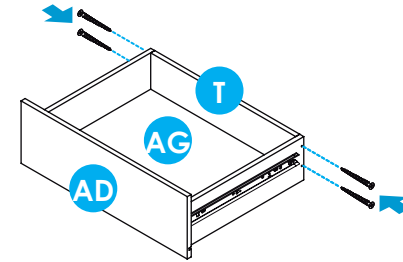

**13** Armado de cajón medio.  
Medium drawer assembly

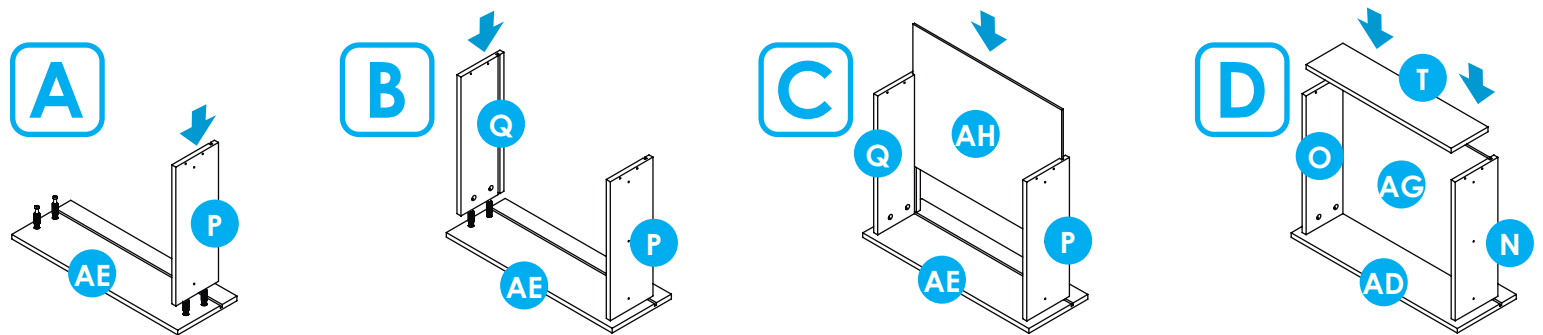

**E** **NOTA:** El riel parte 2 se fija en los laterales del cajón L y M.  
*Note: Slide part 2 is assembled on the sides of part L and M.*

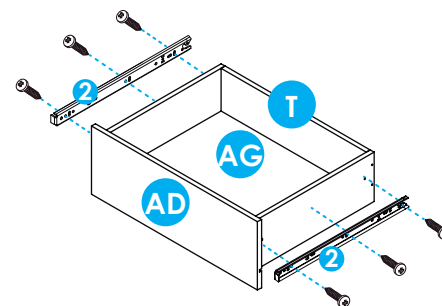

**F** **x4**  
Tornillos ensamble 2"  
Assembly screws 2"

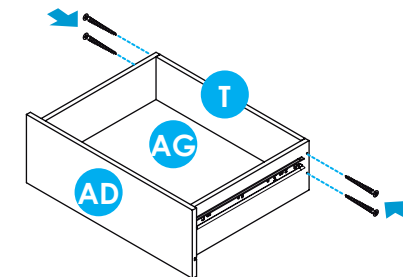



**14** Armado de cajón inferior  
Lower drawer assembly

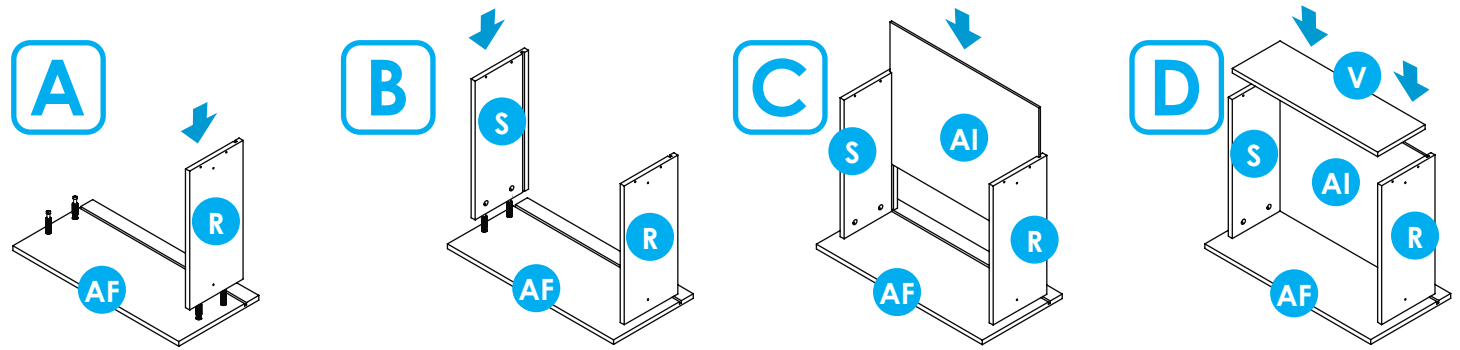

**E** **NOTA:** El riel parte 2 se fija en los laterales del cajón L y M.  
*Note: Slide part 2 is assembled on the sides of part L and M.*

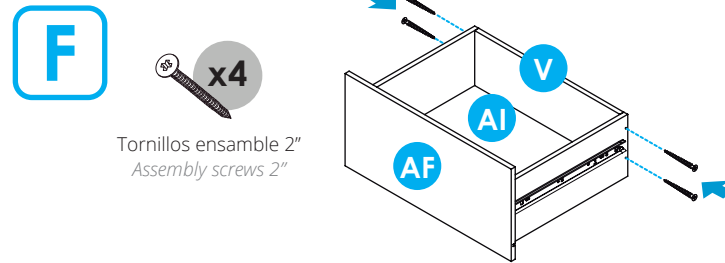
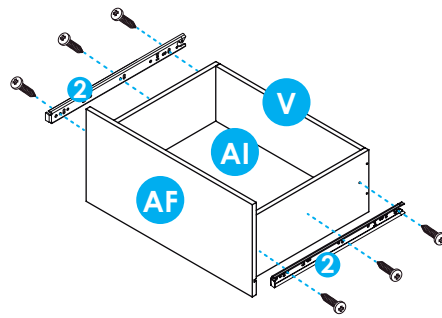

**15** Instalación ángulo metálico.  
Installation of steel angle bracket

**Gire el mueble**  
*Turn the cabinet*

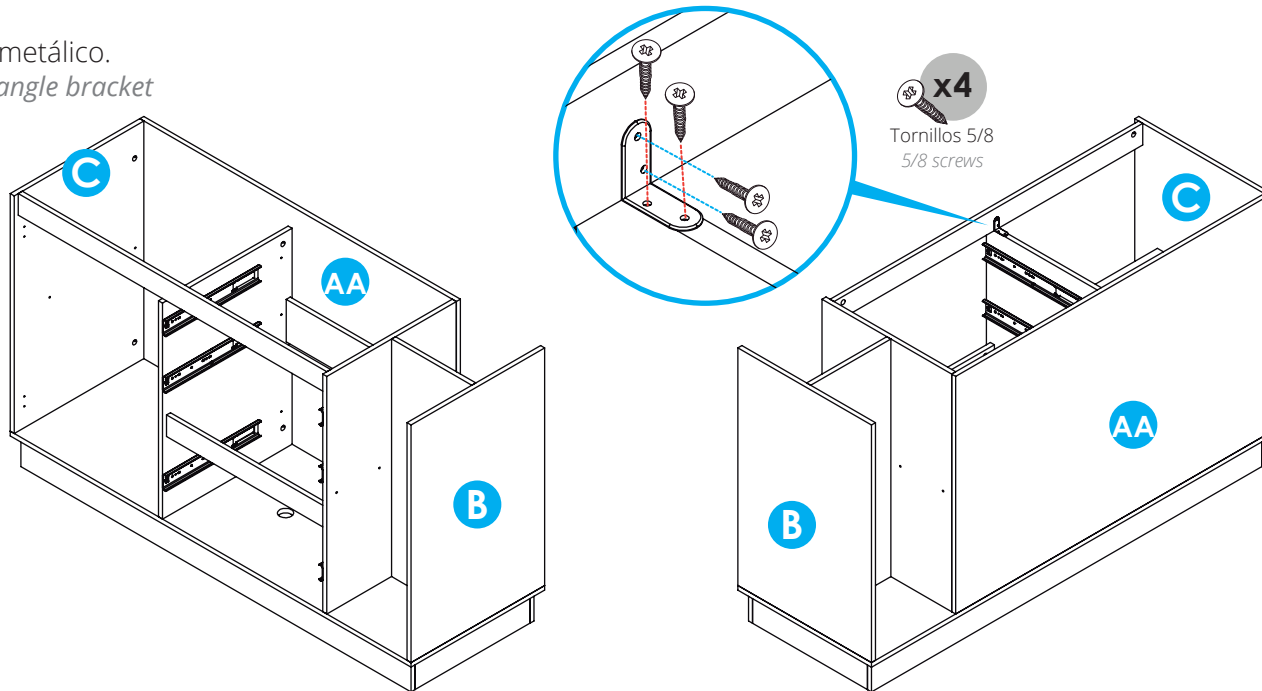

**16****IMPORTANTE:**

Antes de fijar el mueble a piso defina si será tipo isla o si va contra una pared, luego siga las siguientes indicaciones.

**IMPORTANT:** Before fixing the cabinet to the floor, define if it will be an island type or if it goes against a wall, then follow the instructions below.

**Para fijar el mueble al piso****To fix the furniture to the floor**

**A.** Antes de fijar el mueble a piso defina si será tipo isla o si va contra una pared, luego siga las siguientes indicaciones.

**A.** Define where the furniture will go and mark through the perforation of the furniture the place where the metal angle is.

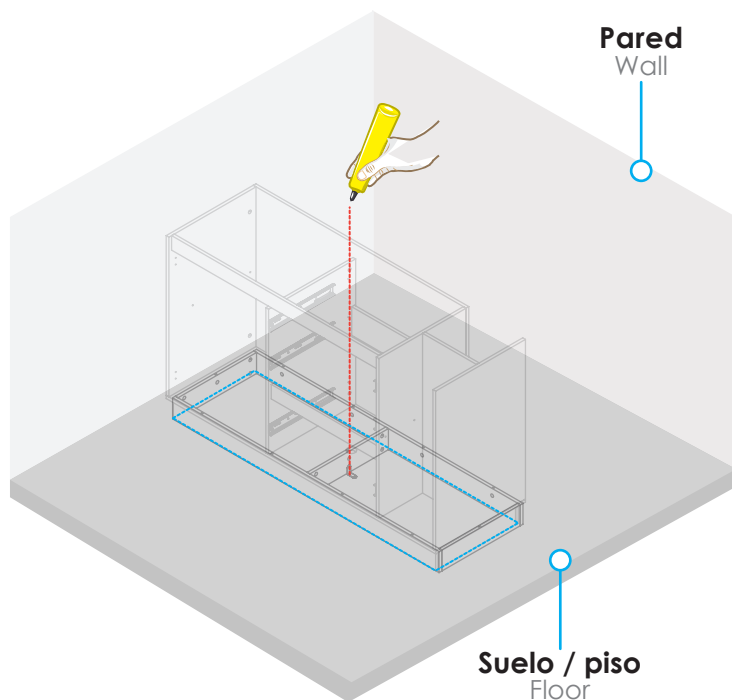

**B.** Taladre el piso utilizando la marca en el suelo cómo guía y con ayuda de una broca para pared (tungsteno) 5/16" perfora el piso, después introduzca el chazo y asegure el mueble con el tornillo y el chazo.

**B.** Drill the floor using the mark on the floor as a guide and with the help of a 5/16" wall drill bit (tungsten) drill the floor, then insert the bolt and secure the furniture with the screw and bolt.

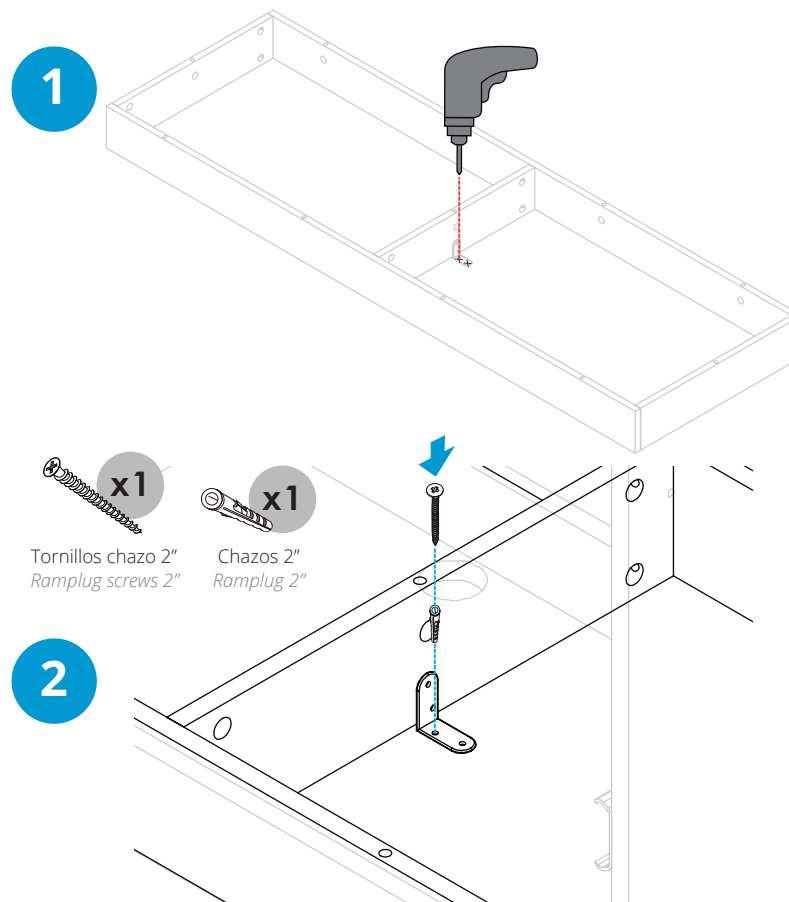

**17**

**\*\* OPCIONAL: Para fijar el mueble a pared:** perfore la pared a la altura indicada de las perforaciones con ayuda de una broca para pared (tungsteno) 3/8", después introduzca el chazo plástico y asegure el mueble con tornillos chazos.

**\*\* OPTIONAL: To secure the cabinet to the wall:** drill the wall at the indicated height of the perforations with the help of a 3/8" wall bit (tungsten), then insert the plastic slab and secure the furniture with screws.

Para este paso necesitarás:

*For this step you will need:*

### Herramientas

*Tools*



Destornillador de estrella  
*Star screwdriver*

### Herrajes

*Fittings*



Tornillos chazo 2"  
*Ramplug screws 2"*

Chazos 2"  
*Ramplug 2"*

Ubique los chazos y los tornillos chazo respetando 5 cm de bajo de la pieza.  
*Locate the ramplug and the ramplug screws respecting 5 cm low of part.*

### IMPORTANTE:

Tenga en cuenta que las paredes deben ser sólidas, de cemento / ladrillo. Si va a instalar el mueble sobre paredes de Drywall (paredes secas), debe utilizar chazos y tornillo de expansión metálico especial para drywall.

### IMPORTANT:

*note that the walls must be solid, cement / brick. In case of drywall instalation, change the ramplug for a drywall metallic Spring Toggle.*

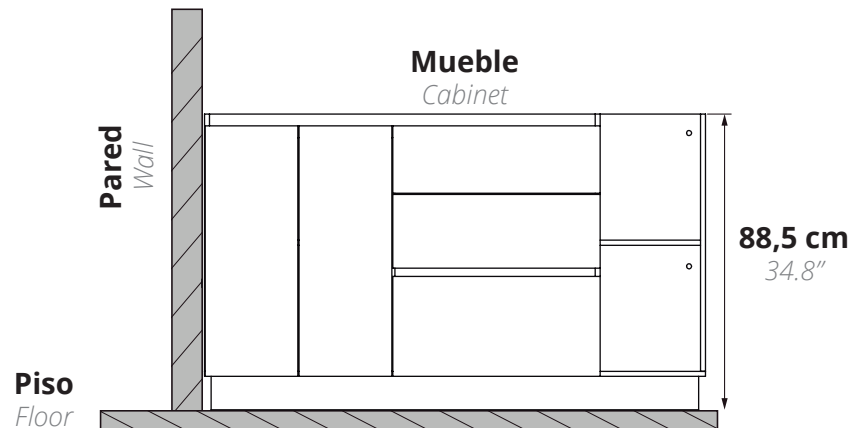

### IMPORTANTE:

Este paso se puede realizar tanto en la pieza B o en la C, dependiendo de donde necesites fijar el mueble.

### IMPORTANT:

*This step can be done on both part B or part C, depending on where you need to fix the furniture.*

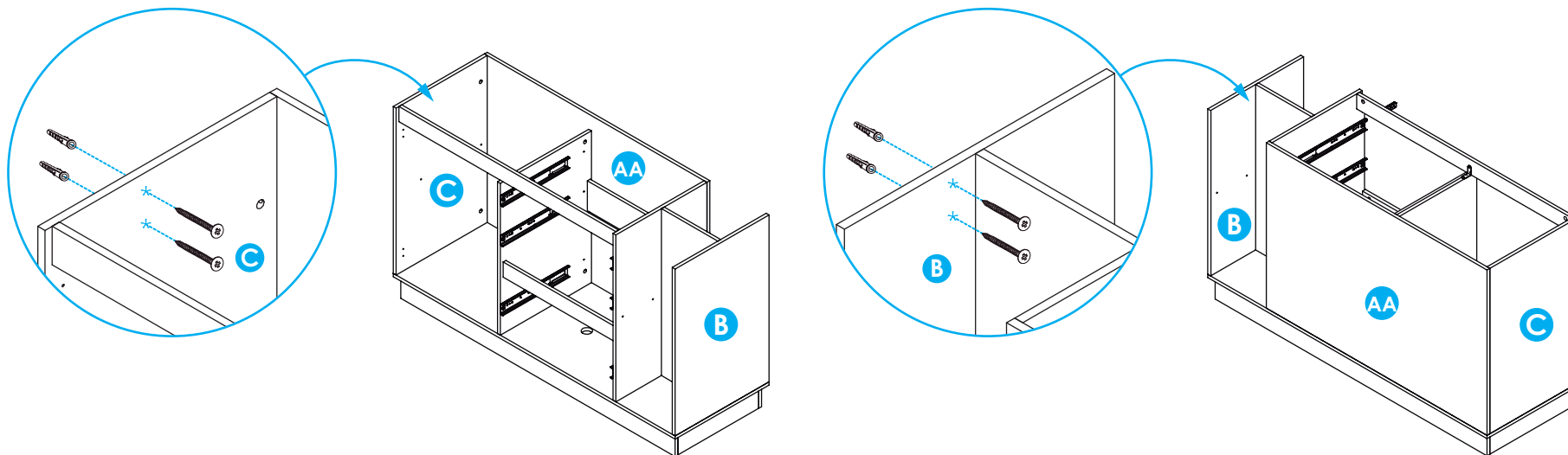

18

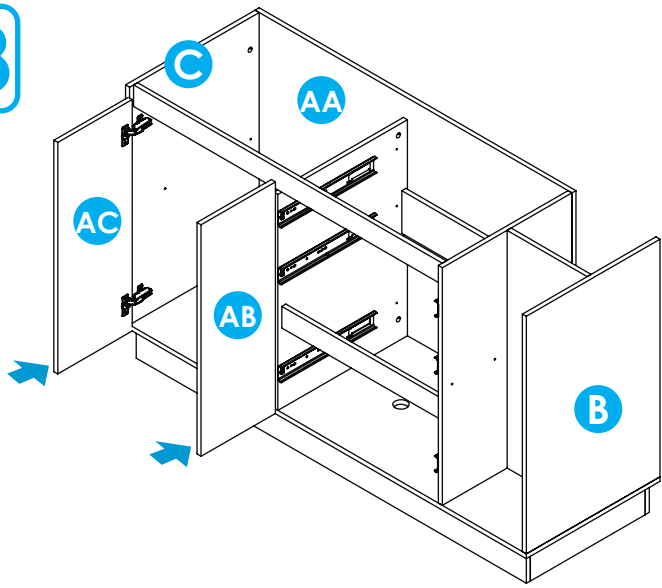

19

x12  
 Soporte entepañó  
 Shelf holder pins

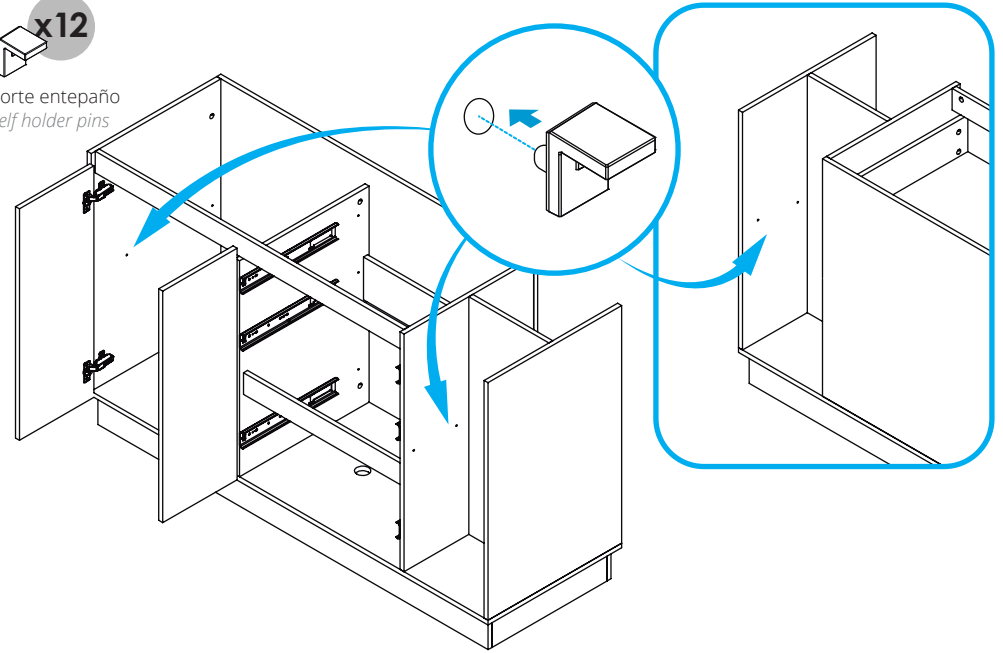

20

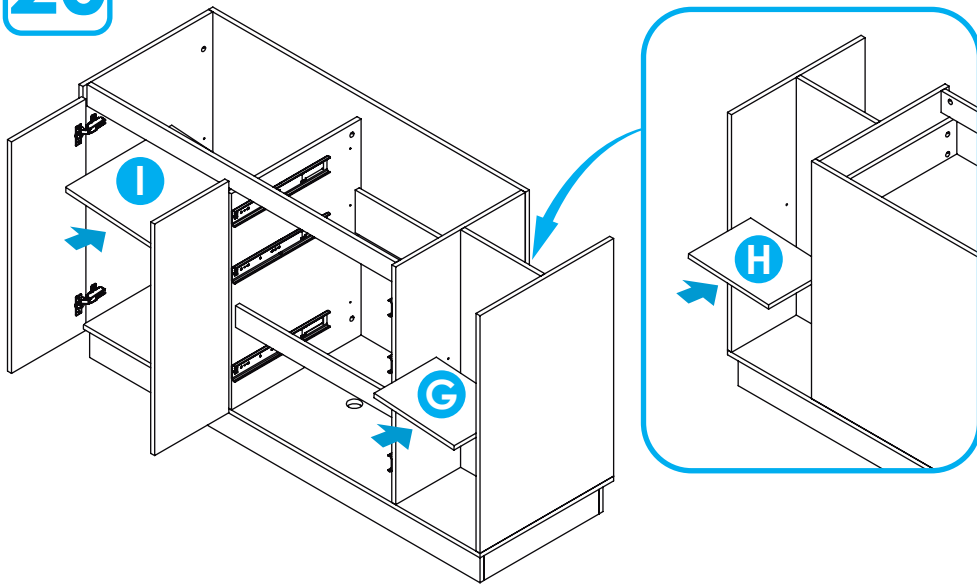

21

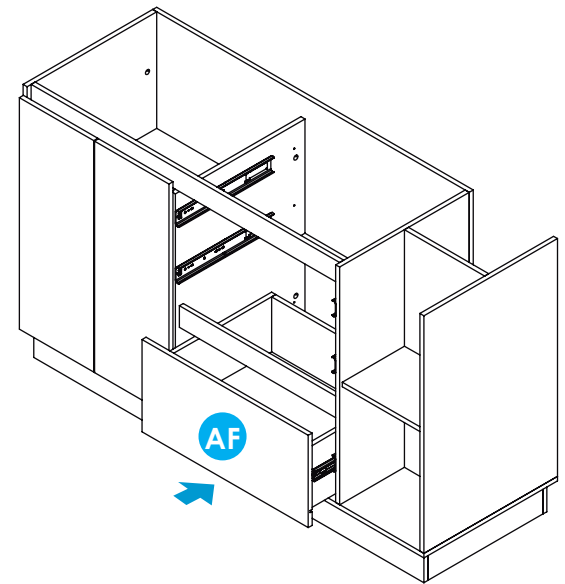

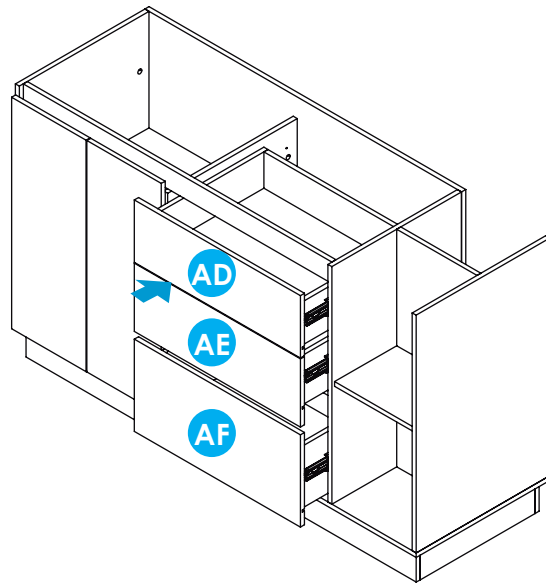
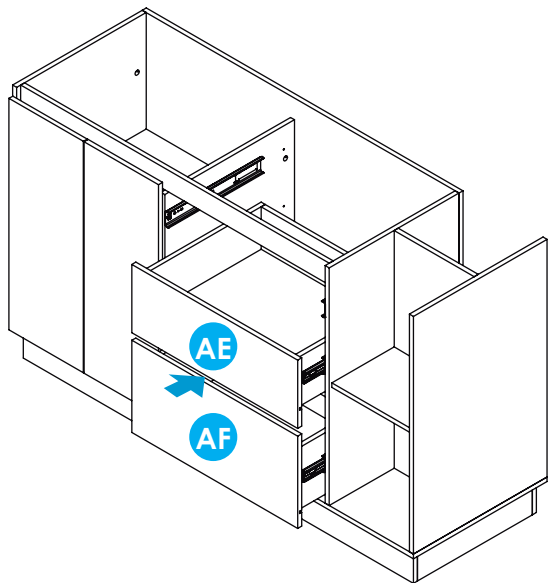

## 22 \* Mueble armado completamente

Fully assembled cabinet

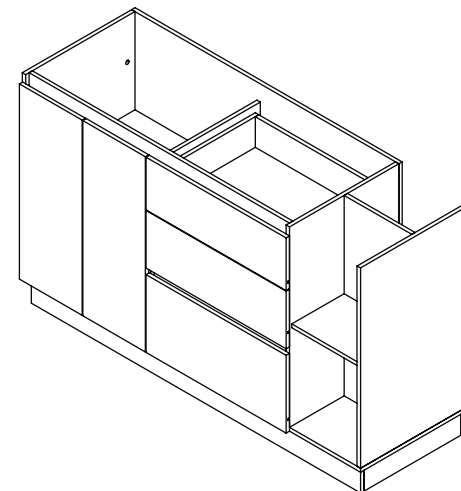

## 24 Nivelación de puertas

Level de doors

**A. Nivelar:** Para nivelar las puertas cuadrándolas al nivel deseado, afloje el tornillo de la bisagra, como lo muestra el detalle. Cuando esté en el lugar indicado, asegure los tornillos bisagra.

**B. Level:** To level the doors, to meet the desired level, loosen the hinge screw, as shown in detail. When in the right place, secure the hinge screws.

**B. Ajuste de profundidad:** le permite llevar las puertas hacia dentro o hacia afuera, aflojando el tornillo de la bisagra, como lo muestra el detalle.

**C. Depth adjustment:** allows you to move the doors in or out, loosening the hinge screw as shown in detail.

**C. Ajuste lateral:** le permite llevar las puertas hacia la derecha o la izquierda, nivelándola con los laterales aflojando o apretando el tornillo de la bisagra como lo muestra el detalle.

**D. Side adjustment:** Allows you to move the doors to the right or left, leveling with the sides loosening or tightening the hinge screw as shown by the detail.

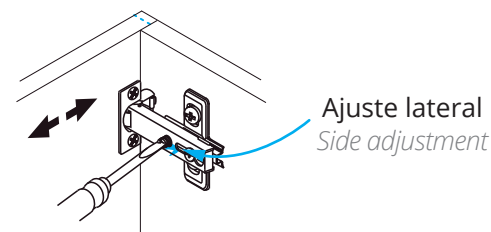
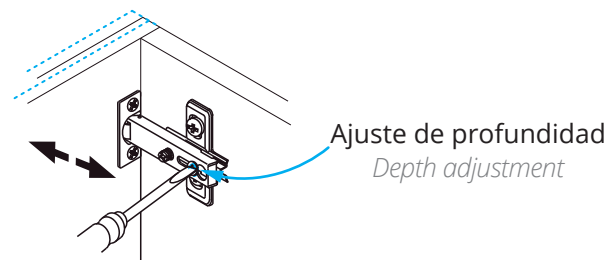
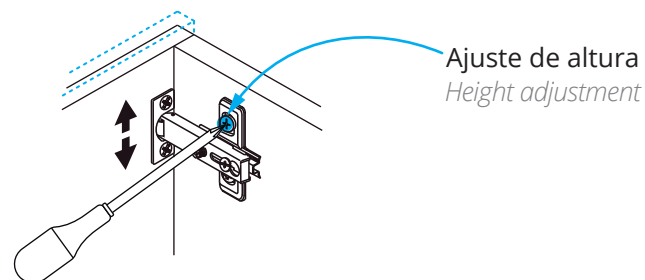

22

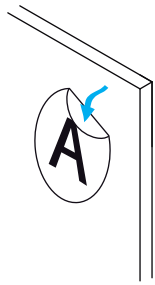

Al terminar de armar desprenda los adhesivos (en caso de que queden residuos de pegante, limpie la superficie con alcohol).

*When you finish assembling, remove the adhesives (in case there is glue residue, clean the surface with alcohol).*

#### **GARANTÍA:**

Para obtener más información sobre la garantía de los muebles, ingrese al enlace o escanee el código QR.

#### **WARRANTY:**

*For more information on the furniture warranty, please enter the link or scan the QR code.*

#### **Link:**

<https://bit.ly/3nf4W6x>

#### **Código QR - Code QR**



#### **Importante:**

Consulte la garantía antes de hacer una reclamación.

#### **Important:**

*Check the warranty before making a claim.*

## **4. Cuidados y mantenimiento**

### *Care and maintenance*

#### **Cuidados y mantenimiento para los muebles**

- Para limpiar el mueble use un trapo seco o humidézcalo en agua y detergente suave, elimine el exceso de agua.
- No pinte ni barnice el mueble.
- No esponga el mueble a la intemperie.
- Evite arrastrarlo, puede ocasionar daños en la estructura.
- Por seguridad, evite que los menores jueguen con el mueble.
- No esponga el mueble a funciones diferentes para lo que fueron diseñados. Ejemplo: sentarse en el mueble.

#### **Care and maintenance for cabinet**

- *To clean the cabinet, use a dry cloth or moisten it in water and mild detergent.*
- *Do not paint or varnish the furniture.*
- *Do not expose the furniture to the out side.*
- *Avoid dragging it, it can cause damage to the structure.*
- *For safety, avoid children playing with the furniture.*
- *Do not expose the furniture to different functions for which they were not designed. Example: sit on the furniture.*

**si necesita ayuda comuníquese con su asesor comercial firplak**  
*if you need help, contact your business advisor firplak*



[www.firplak.com](http://www.firplak.com)

Sede principal: Calle 29 N° 41-15 (Itagüí - Antioquia)