

INSTRUCCIONES DE ENSAMBLE

ASSEMBLY INSTRUCTIONS



*** Instrucciones de Instalación:** Mueble cubo más cajón Godai lvm 63 x 48 cm / mueble para el baño
Installation Instructions: GODAI CUBE PLUS DRAWER 25" x 19" / bathroom sink cabinet

RECOMENDACIONES PREVIAS / Previous recommendations:



Si las paredes donde va a ubicar el mueble son en drywall, debe adquirir chazos y tornillos especiales para su instalación.

If the walls where you are locating the cabinet are in drywall, you must purchase special ramplug and screws for installation.



No golpee ni martille todo el mueble, sólo donde se le indica.

Do not strike or hammer all the cabinet, only where directed.



No pinte ni barnice el mueble.

Do not paint or varnish the cabinet.



No arrastre ni se suba al mueble, si necesita moverlo por favor levántelo.

Do not drag or stand on the cabinet, if you need to move it please lift up.



Lea detenidamente y siga en orden consecutivo las instrucciones de armado.

Read carefully and follow in sequence the assembly instructions.



No expongas el mueble a la intemperie, ni al calor.

Do not expose the cabinet to the outdoors or the heat.

IMPORTANTE:

Antes de empezar a ensamblar el mueble, lea detenidamente las instrucciones. Pre-ensamble el mueble sobre su caja, para no rayarlos. Si falta una parte o piensa que esta defectuosa no devuelva el mueble al almacén; le agradecemos llamar al (5-74) 444 17 71, o comuníquese con su asesor principal, también nos pueden escribir a servicioalcliente@firplak.com.

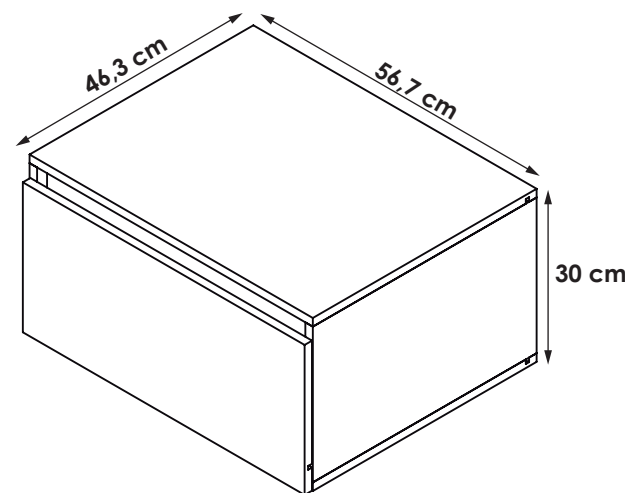

Sello de calidad / Quality seal

Por favor no deseche el instructivo del mueble, este le servirá para cualquier reclamo con respecto a la garantía del mismo.

Please do not discard the cabinet's instructions, it will serve you for any claim regarding its warranty.



IMPORTANT: Before you start to assemble the cabinet, please read the instructions. Pre assembly the cabinet on its box, to prevent scratches. If a part is missing or damaged, do not return the furniture to the store, please call the (5-74) 444 17 71 or contact your sales assistant. also you can write to servicioalcliente@firplak.com.

1. Identificación de las partes

Parts identification

HERRAMIENTAS REQUERIDAS / Tools required :

* No incluido.
Not included.

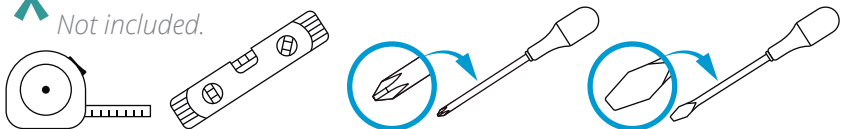

A Mueble para lavamanos. Cabinet sink.



Tabla de piezas
Parts Chart

Pieza / Part	Cantidad / Total
A	1
B	1
C	1
D	1
E	1
F	1
G	1
H	1
I	1
J	1
K	1
L	1
Cantidad Total	Desde From hasta to
12	A L

B Identificación de herrajes. Hardware identification

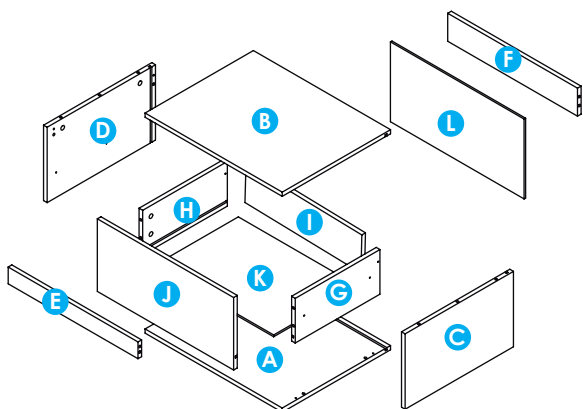

* Tenga precaución al abrir la bolsa de herrajes de no perder ningún elemento. Compruebe si el contenido de las piezas es el correcto.

Be carefull opening the screw bag so you do not lose any. Chek if the number of screws is right.

C Recomendaciones de ensambles. Assembly recommendations

Instalación de minifix y pernos de minifix Installing the minifix cams and spreading minifix

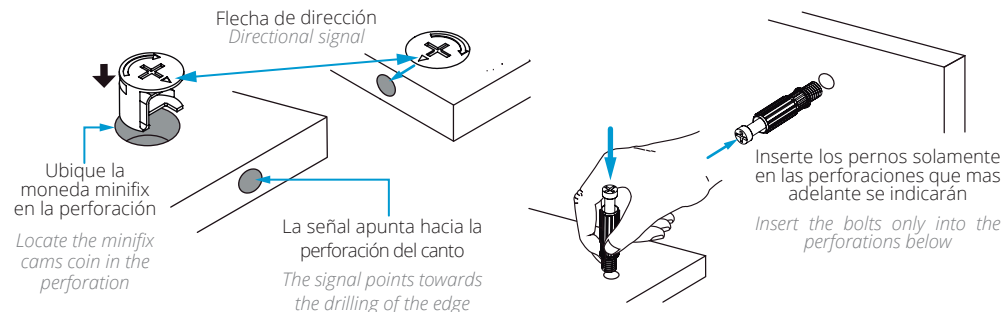

Ajustes de partes Parts adjustments



Tarugos Wooden pins

Introduzca los tarugos solo hasta su tope máximo
Insert the wooden pins only up to their maximum peak

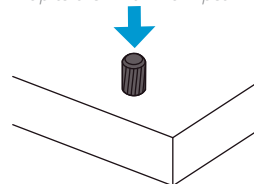

Inserte los tarugos solamente en las perforaciones que más adelante se indicarán
Insert the wooden pins only into the perforations below

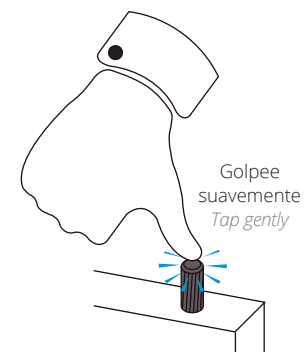
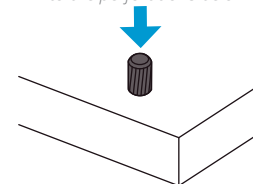

2. Preparación de las partes

Preparation of the parts

Se recomienda preparar las partes del mueble sobre la caja o una superficie lisa para no rayarlo.

It is recommended to prepare the parts of the cabinet on the box or on a flat surface to not scratch it.

Para este paso necesitarás:

For this step you will need:

Herramientas

Tools



Destornillador de estrella
Star screwdriver

Herrajes

Fittings



x2

Rieles
Slides

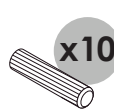

x10

Tarugos
Wooden pins



x12

Pernos Minifix
Spreading bolt



x12

Minifix
Minifix cams

IMPORTANTE:

Antes de iniciar el pre ensamblaje, separar el riel cuidadosamente, que consta de dos partes (**1 y 2**). Para separar, presione la palanca hacia abajo como indica la imagen 1.

IMPORTANT:

*Before starting the pre assembly, separate the slides carefully, the slides are made of two parts (**1 and 2**). To separate them, press the lever down as shown in image 1*

Imagen 1

Image 1

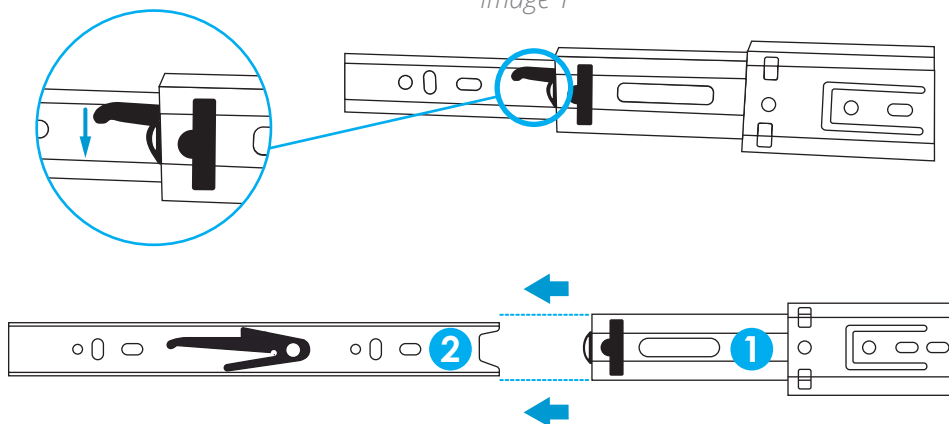

1

NOTA: El riel parte 1 se fija en los laterales del mueble C y B.

Note: Slide part 1 is assembled on the sides of part C and B.

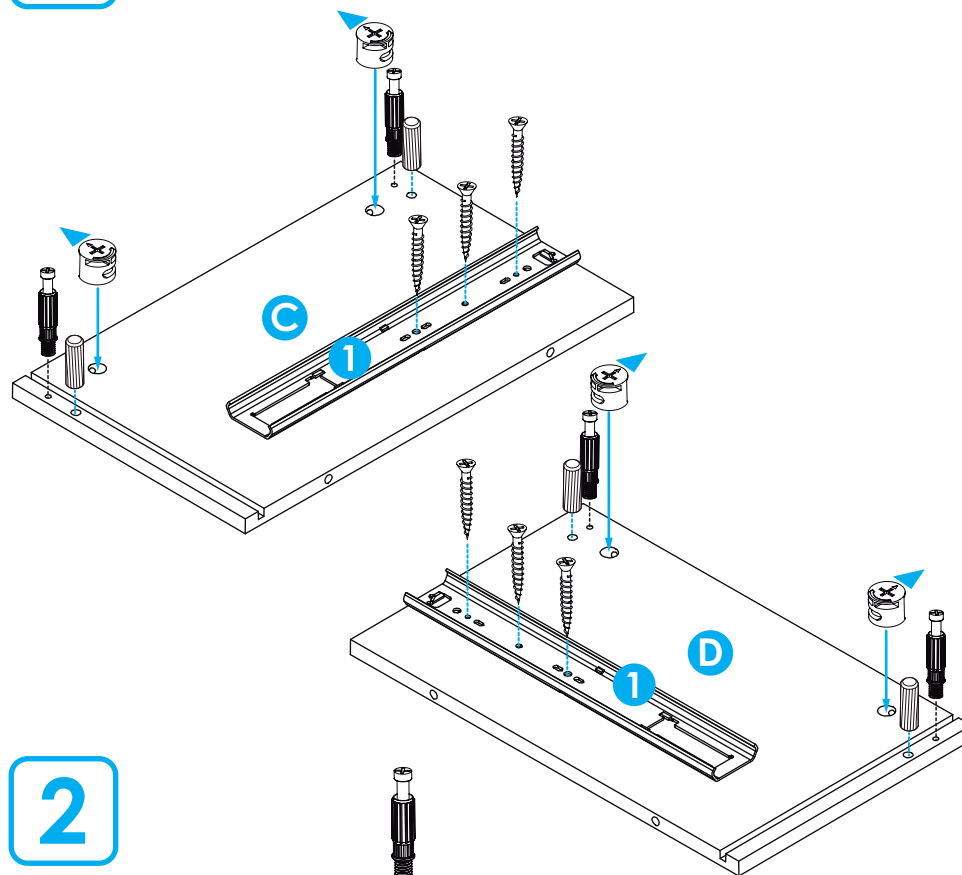

2

IMPORTANTE:

De un correcto armado de los muebles depende su buen funcionamiento.

IMPORTANT:

A proper assembly of the furniture guarantees the performance of the hinges.

3

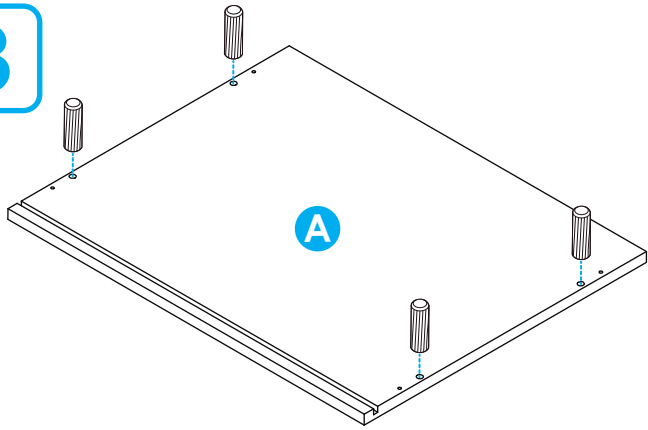

4

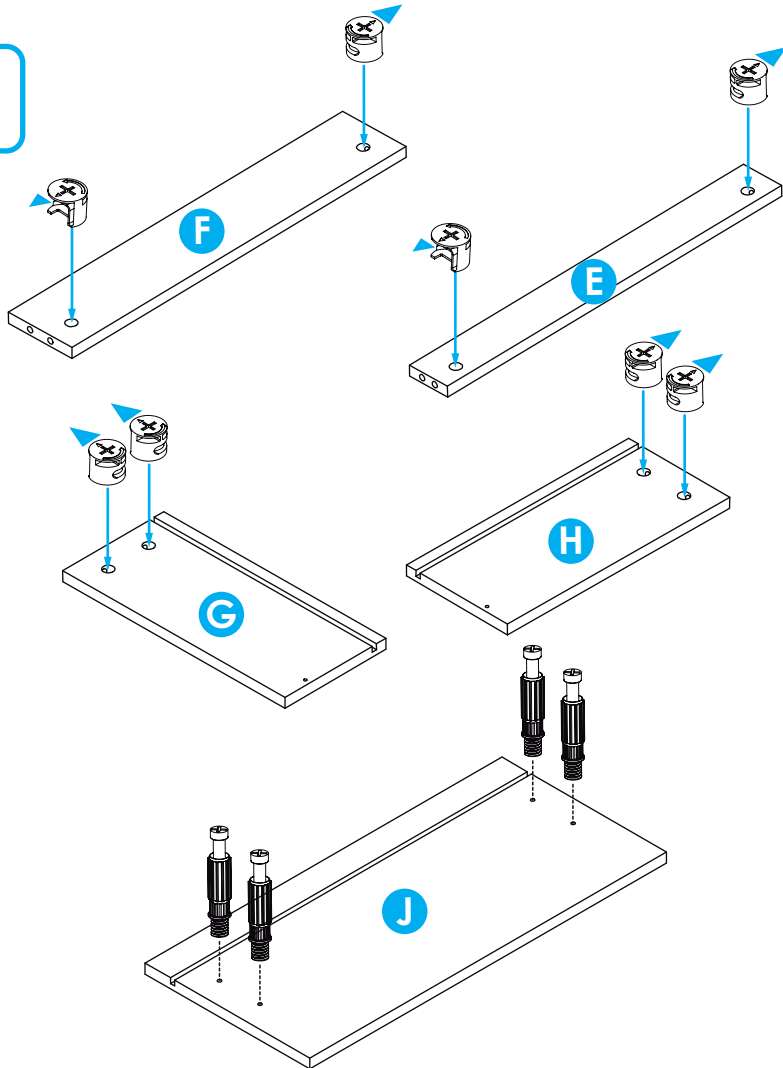

3. Preparación para ensamblar

Assembly steps

Se recomienda armar el mueble sobre la caja o una superficie lisa para no rayarlo.

It is recommended to assemble the product top of the box or on a flat surface to not scratch it.

Para este paso necesitarás:

For this step you will need:

Herramientas

Tools

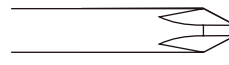

Destornillador de estrella
Star screwdriver

Herrajes

Hardware



x2

Rieles
Rails



x4

Tornillos ensamble 2"
Assembly screws 2"

IMPORTANTE:

A medida que vaya encajando las piezas, ajuste con el destornillador.

IMPORTANT:

as the pieces fit together, adjust with the screwdriver.

1

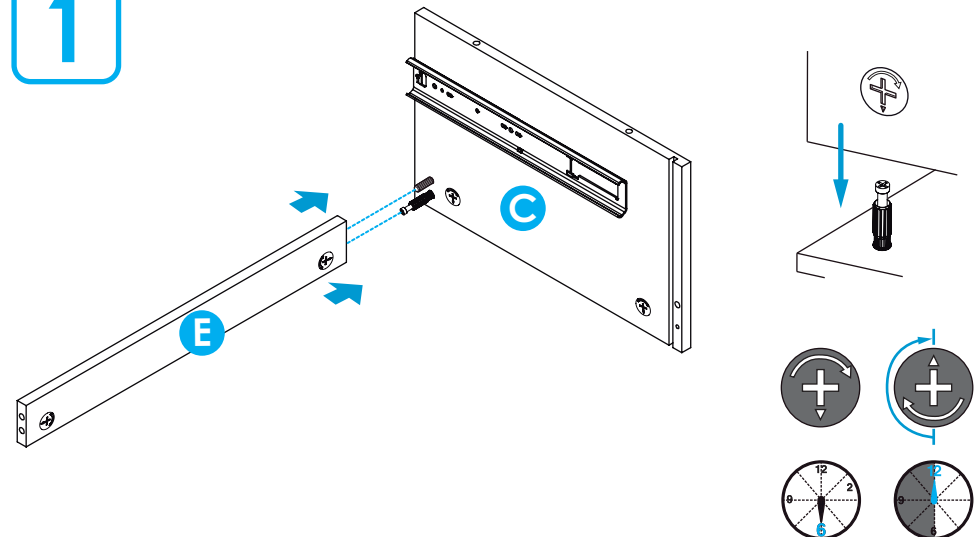

2

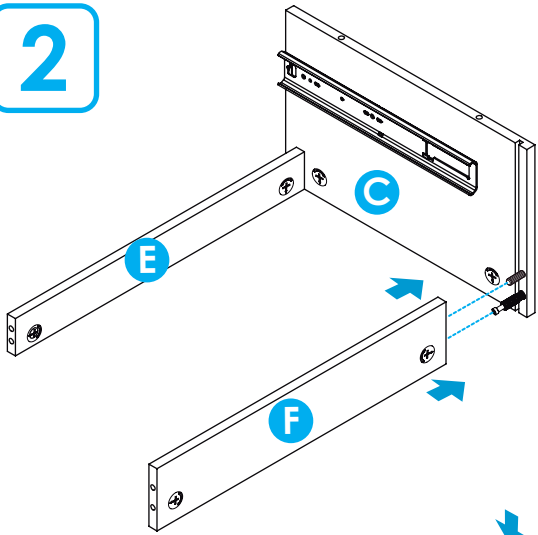

3

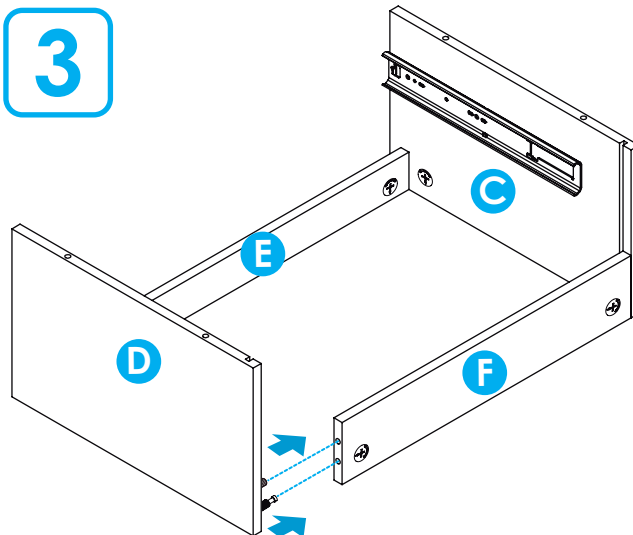

4

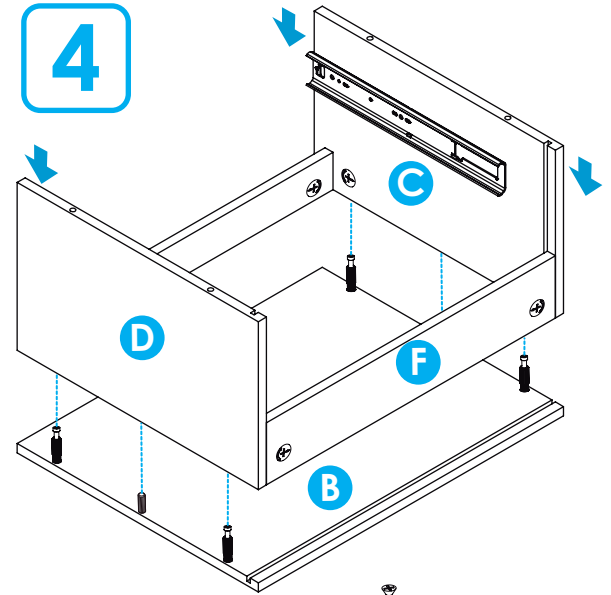

5

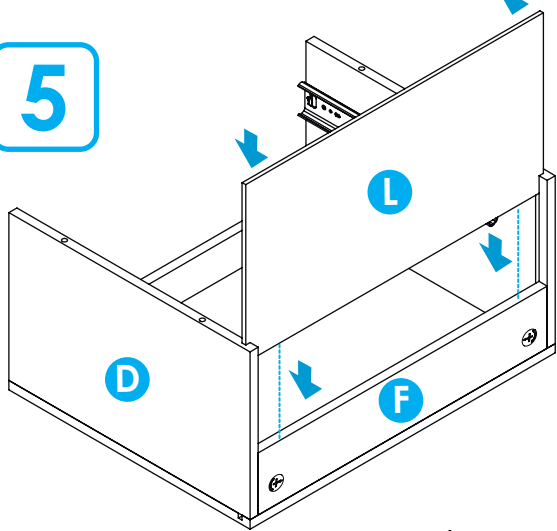

6

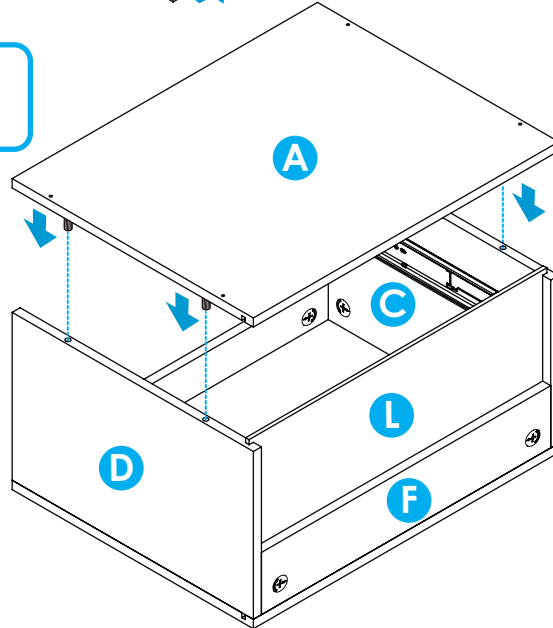

7

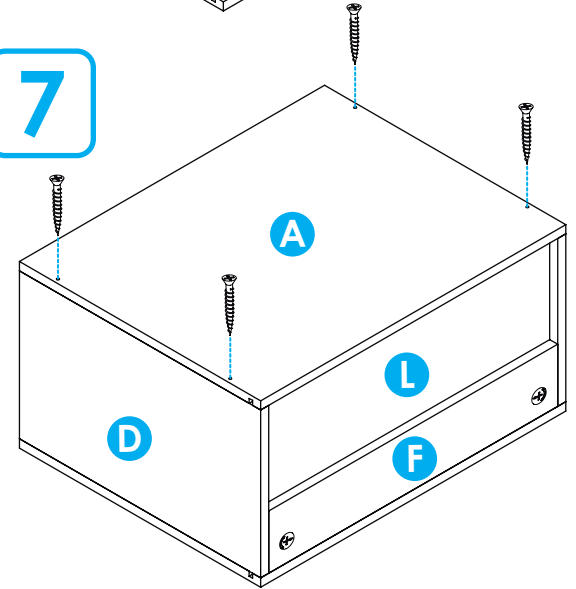

8

Girar mueble
Turn cabinet

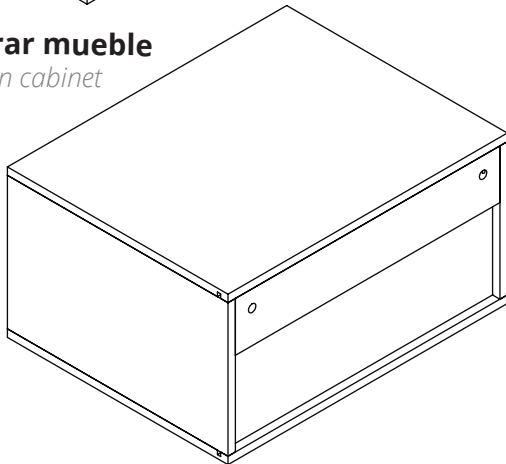

9

Ensamble cajón: Para este paso necesitarás.
Drawer assembly: For this step you will need

Herramientas

Tools



Herrajes

Hardware

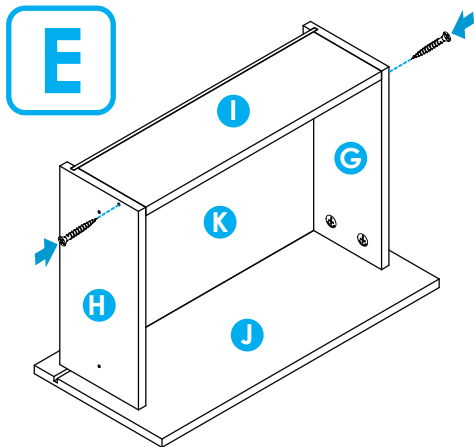
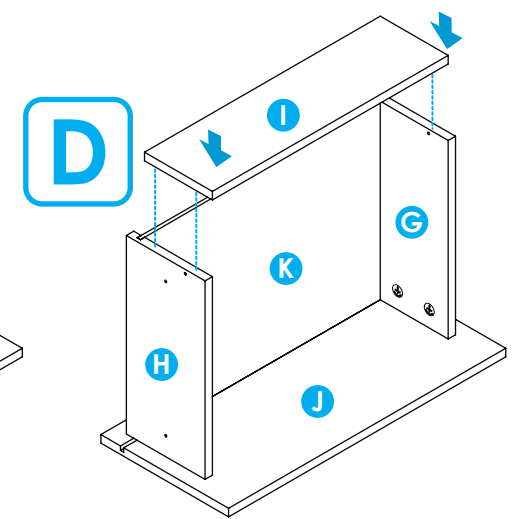
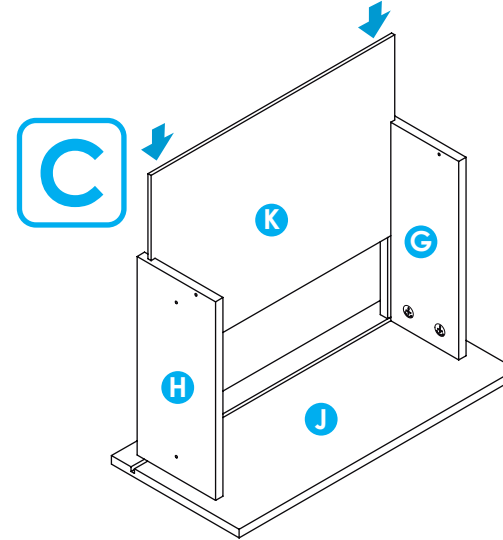
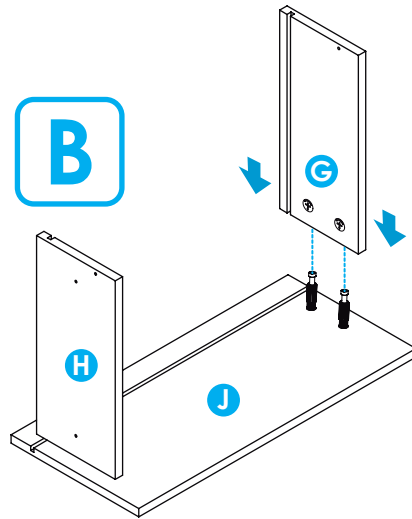
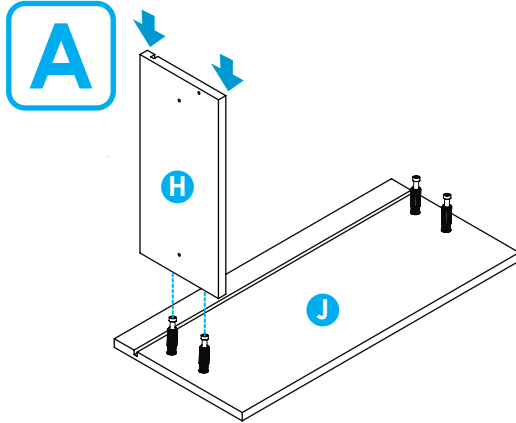
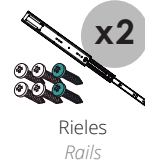

F **NOTA:** El riel parte 2 se fija en los laterales del mueble G y H
Note: Slide part 2 is assembled on the sides of part G and H.

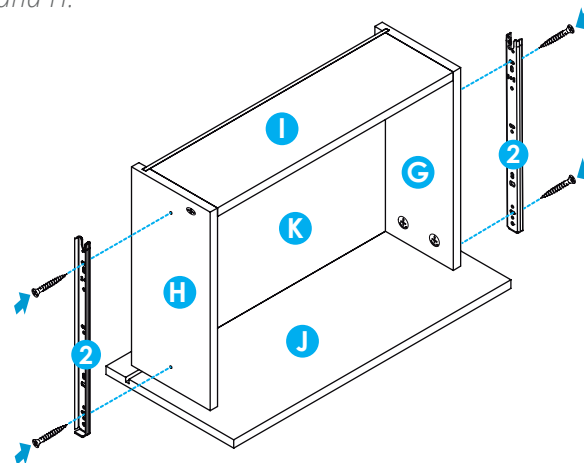

10 **Para fijar el mueble:** perfora la pared a la altura indicada de las perforaciones con ayuda de una broca para pared (tungsteno) 3/8", después introduzca el chazo plástico y asegure el mueble con tornillos chazos.

To secure the cabinet: drill the wall at the indicated height of the perforations with the help of a 3/8" wall bit (tungsten), then insert the plastic slab and secure the furniture with screws.

Para este paso necesitarás:

For this step you will need:

Herramientas

Tools



Destornillador de estrella
Star screwdriver

Herrajes

Fittings



x2

Tornillos chazo 2"
Ramplug screws 2"



x2

Chazos 2"
Ramplug 2"

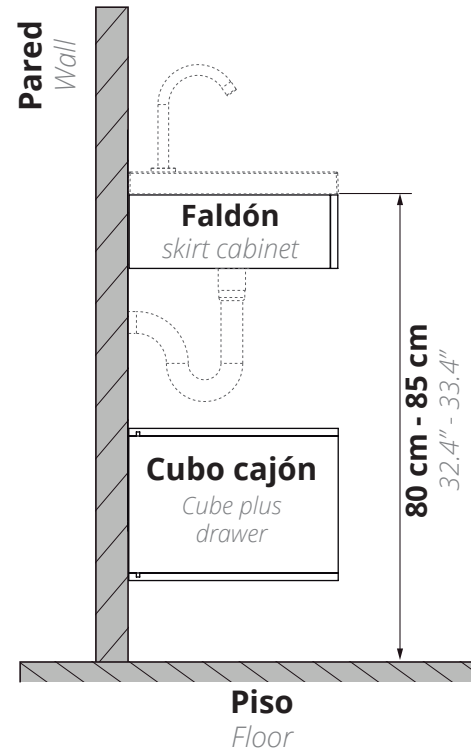
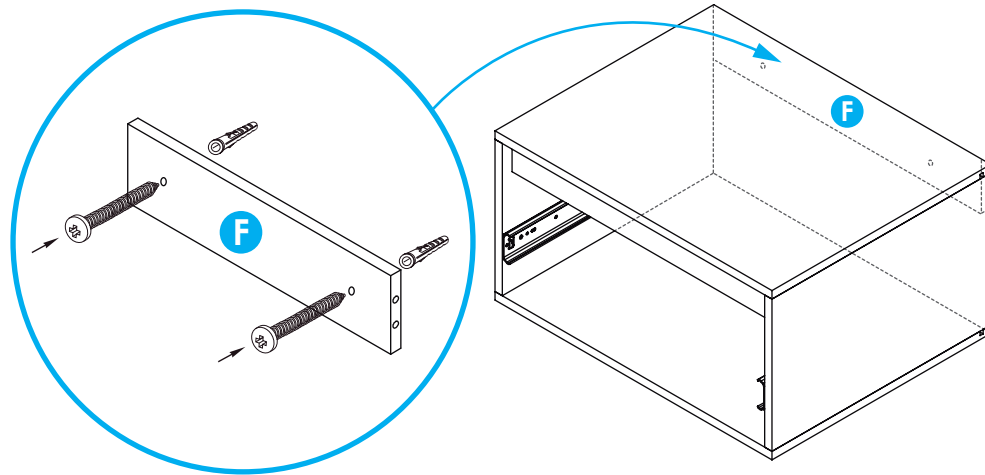

IMPORTANTE:

Tenga en cuenta que las paredes deben ser sólidas, de cemento / ladrillo. Si va a instalar el mueble sobre paredes de Drywall (paredes secas), debe utilizar chazos y tornillo de expansión metálico especial para drywall.

IMPORTANT:

note that the walls must be solid, cement / brick. In case of drywall installation, change the ramplug for a drywall metallic Spring Toggle.

IMPORTANTE:

Ubique los chazos y los tornillos chazo respetando 5 cm de bajo de la pieza B antes de meter el cajón.

IMPORTANT:

Locate the ramplug and the ramplug screws respecting 5 cm low of part B before inserting the drawer.

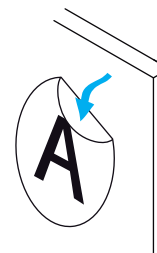

Al terminar de armar desprenda los adhesivos (en caso de que queden residuos de pegante, limpie la superficie con alcohol).

When you finish assembling, remove the adhesives (in case there is glue residue, clean the surface with alcohol).

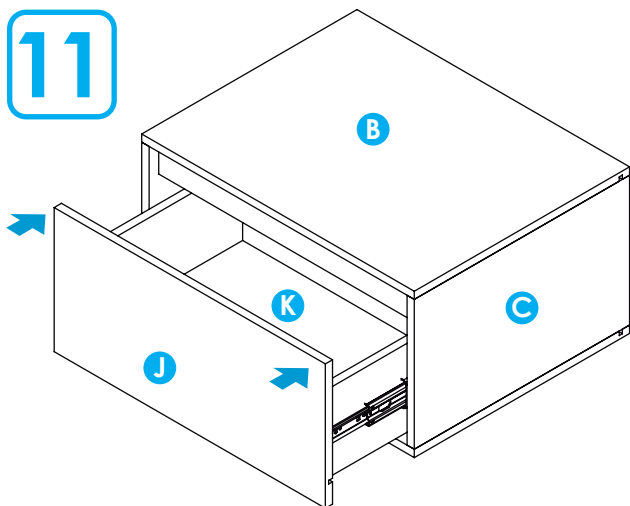
11**12**

Mueble armado completamente
Fully assembled cabinet

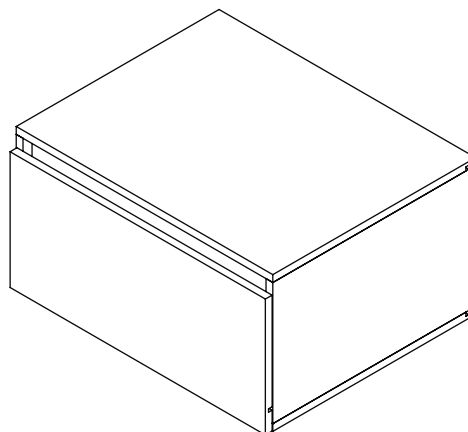

IMPORTANTE:

Recuerde ajustar las dos monedas internas de los minifix para completar el armado del mueble

IMPORTANT:

Remember to adjust the two internal coins of the minifix cams to complete the assembly of the cabinet

4. Cuidados y mantenimiento

Care and maintenance

Cuidados y mantenimiento para los muebles

- Para limpiar el mueble use un trapo seco o humedézcalo en agua y detergente suave, elimine el exceso de agua.
- No pinte ni barnice el mueble.
- No esponga el mueble a la intemperie.
- Evite arrastrarlo, puede ocasionar daños en la estructura.
- Por seguridad, evite que los menores jueguen con el mueble.
- No esponga el mueble a funciones diferentes para lo que fueron diseñados. Ejemplo: sentarse en el mueble.

Care and maintenance for cabinet

- *To clean the cabinet, use a dry cloth or moisten it in water and mild detergent.*
- *Do not paint or varnish the furniture.*
- *Do not expose the furniture to the out side.*
- *Avoid dragging it, it can cause damage to the structure.*
- *For safety, avoid children playing with the furniture.*
- *Do not expose the furniture to different functions for which they were not designed. Example: sit on the furniture.*

si necesita ayuda comuníquese con su asesor **comercial firplak** tel:
4441771 (ext: 108). tel: 4441771 (ext: 131)

*if you need help, contact your **business advisor firplak** tel: 4441771
 (ext: 131)*



www.firplak.com

Sede principal: Calle 29 N° 41-15 (Itagüí - Antioquia), Teléfono: (574) 444 17 71

Arma tu MIX

Build your MIX

Combina los muebles de la línea Godai como quieras, conoce a continuación algunos ejemplos y deja volar tu imaginación con mas de 100 combinaciones

Combine the GODAI cabinets, using the different modules. Let your imagination fly with more than 100 combinations

1 Mueble Godai 63x48 + **entrepañó**
Godai 25"x19" cabinet + shelf

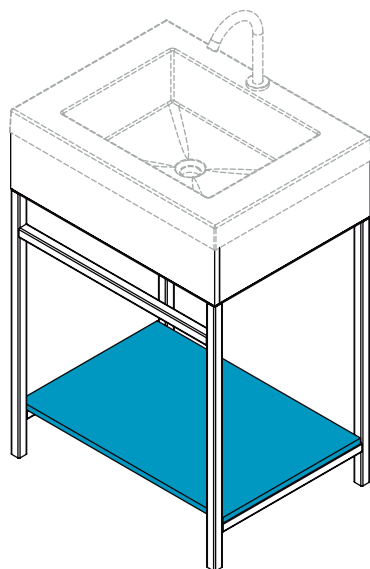

2 Mueble Godai 63x48 + **cubo**
Godai 25"x19" cabinet + cube

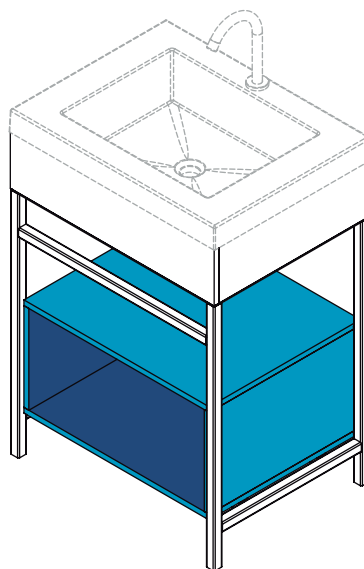

3 Mueble Godai 63x48 + **cubo cajón**
Godai 25"x19" cabinet + drawer cube

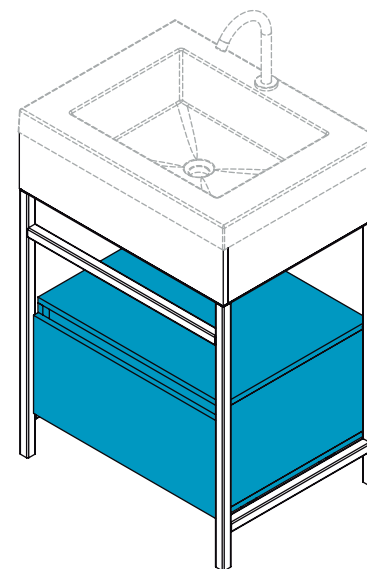

4 Faldón + **cubo** 63x48 flotantes
Skirt + cube 25"x19" floating

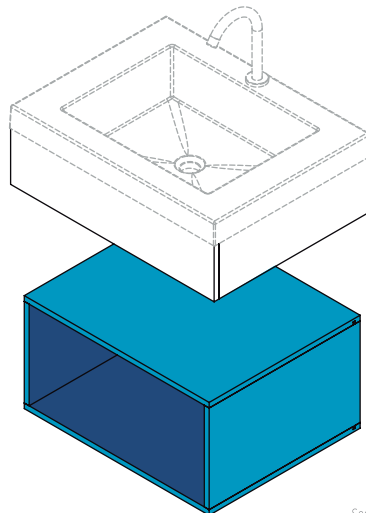

5 Faldón + **cubo cajón** 63x48 flotantes
Floating skirt + drawer cube 25"x19"

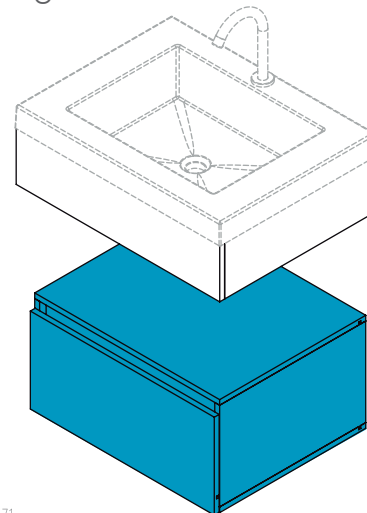

www.firplak.com

Sede principal: Calle 29 N° 41-15 (taguá - Antioquia), Teléfono: (574) 444 17 71

6 Otras combinaciones
Other combinations

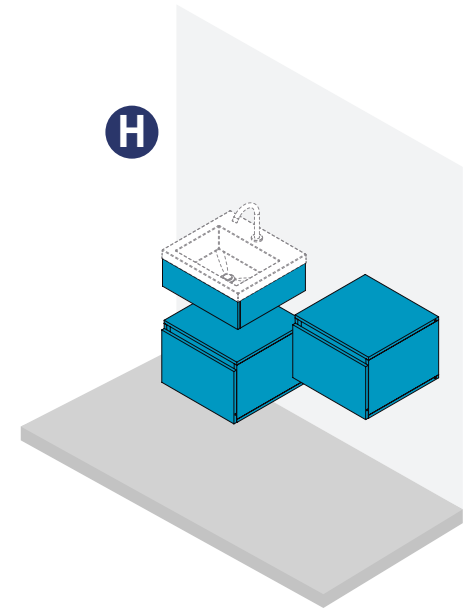
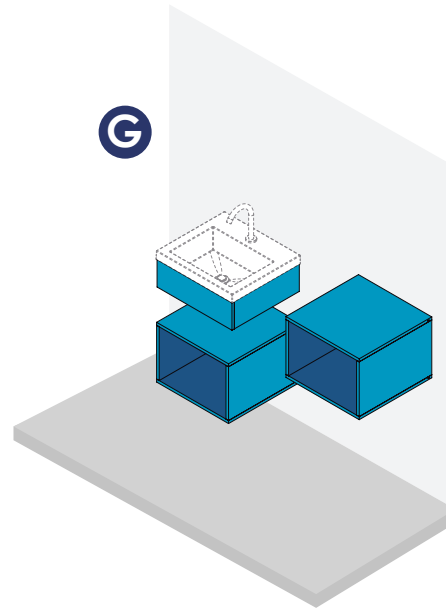
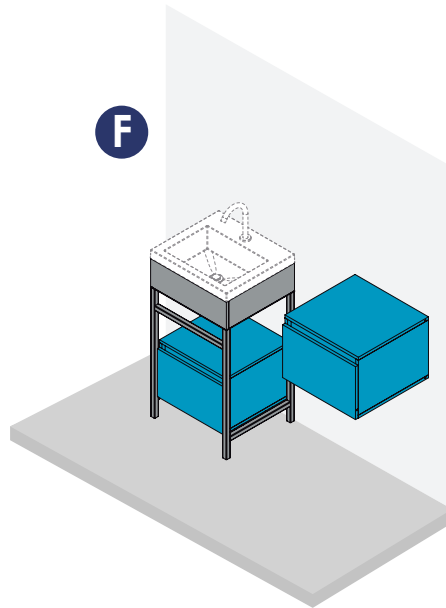
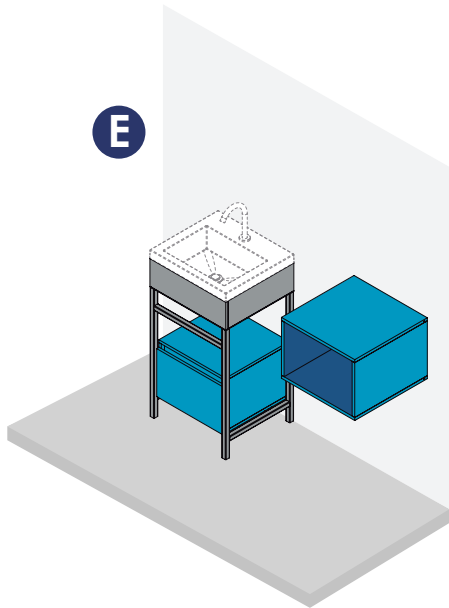
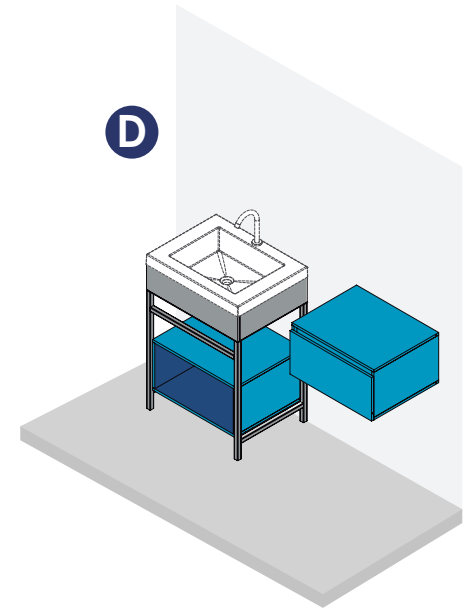
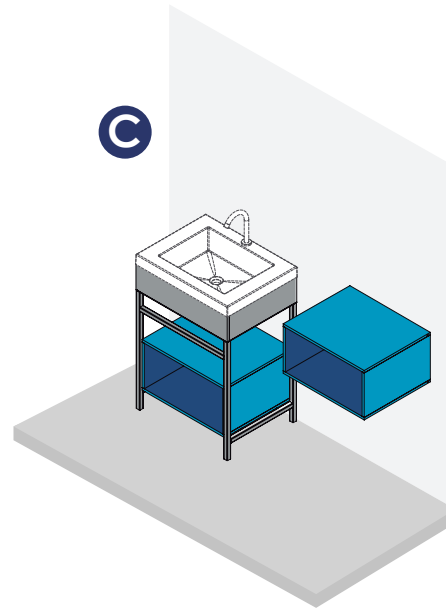
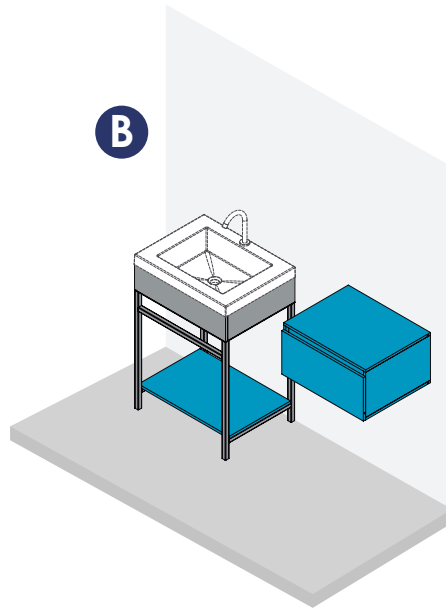
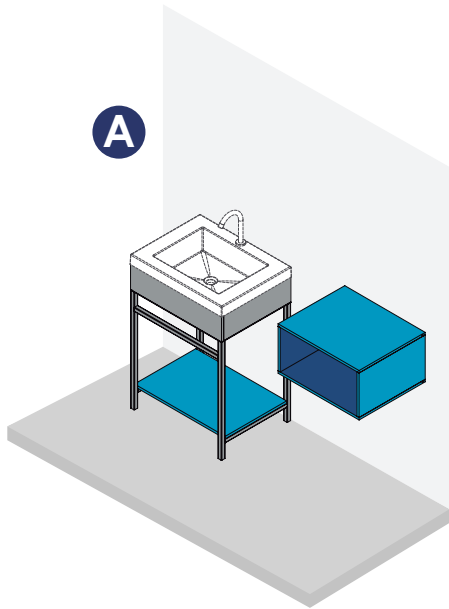

www.firplak.com

Sede principal: Calle 29 N° 41-15 (Itagüí - Antioquia), Teléfono: (574) 444 17 71

Más de 100 combinaciones
More than 100 combinations