

INSTRUCCIONES DE ENSAMBLE

ASSEMBLY INSTRUCTIONS



* **Instrucciones de Instalación:** Mueble Tiziano lvm 124 x 48 cm / mueble para el baño
Installation Instructions: TIZIANO CABINET 49" x 19" / bathroom sink cabinet

RECOMENDACIONES PREVIAS / Previous recommendations:



No golpee ni martille todo el mueble, sólo donde se le indica.
Do not strike or hammer all the cabinet, only where directed.



No pinte ni barnice el mueble.
Do not paint or varnish the cabinet.



No arrastre ni se suba al mueble, si necesita moverlo por favor levántelo.
Do not drag or stand on the cabinet, if you need to move it please lift up.



Lea detenidamente y siga en orden consecutivo las instrucciones de armado.
Read carefully and follow in sequence the assembly instructions.



No expongas el mueble a la intemperie, ni al calor.
Do not expose the cabinet to the outdoors or the heat.

IMPORTANTE:

Antes de empezar a ensamblar el mueble, lea detenidamente las instrucciones. Arme el mueble sobre su caja, para no rayarlos. Si falta una parte o piensa que esta defectuosa no devuelva el mueble al almacén; le agradecemos llamar al **(5-74) 444 17 71**, o comuníquese con su asesor principal, también nos pueden escribir a servicioalcliente@firplak.com.

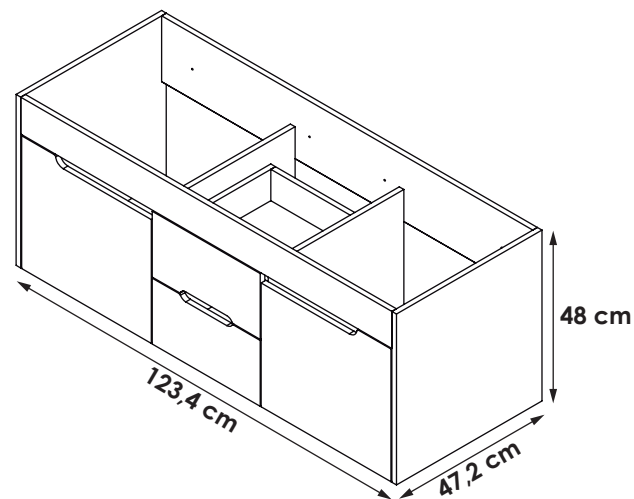

Sello de calidad / Quality seal

Por favor no deseche el instructivo del mueble, este le servirá para cualquier reclamo con respecto a la garantía del mismo.

Please do not discard the cabinet's instructions, it will serve you for any claim regarding its warranty.



IMPORTANT: Before you start to assemble the cabinet, please read the instructions. Assemble the cabinet on its box, to prevent scratches. If a part is missing or damaged, do not return the furniture to the store, please call the **(5-74) 444 17 71** or contact your sales assistant. also you can write to servicioalcliente@firplak.com.

1. Identificación de las partes

Parts identification

HERRAMIENTAS REQUERIDAS / Tools required :

* No incluido.
Not included.

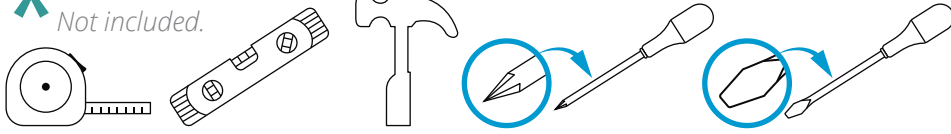

A Mueble para lavamanos. Cabinet sink.



Tabla de piezas
Parts Chart

Pieza / Part	Cantidad / Total
A	1
B	1
C	1
D	1
E	1
F	1
G	1
H	1
I	1
J	1
K	1
L	1
M	1
N	1
O	1
P	1
Q	1
R	1
S	1
T	1
Cantidad Total	Desde A hasta T
20	

B Identificación de herrajes. Hardware identification

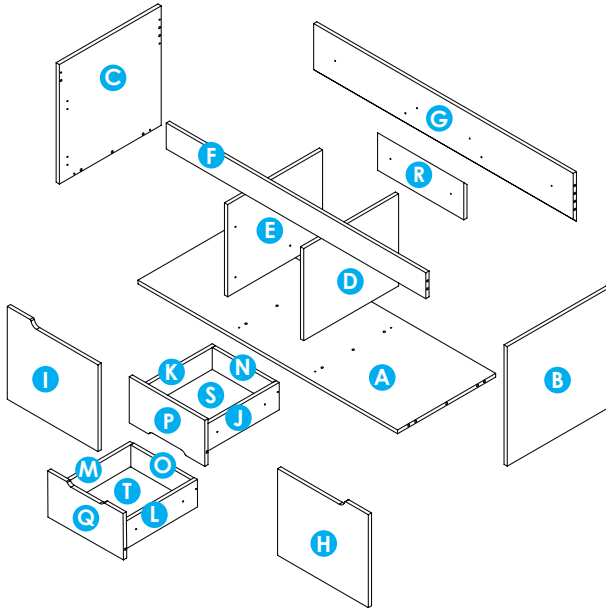
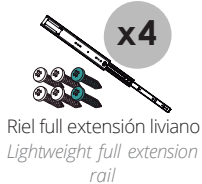

x2

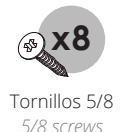
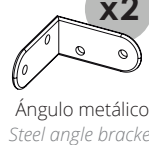

* Tenga precaución al abrir la bolsa de herrajes de no perder ningún elemento. Compruebe si el contenido de las piezas es el correcto.

Be carefull opening the screw bag so you do not lose any. Chek if the number of screws is right.

C Recomendaciones de ensambles. Assembly recommendations

Instalación de minifix y pernos de minifix

Installing the minifix cams and spreading minifix

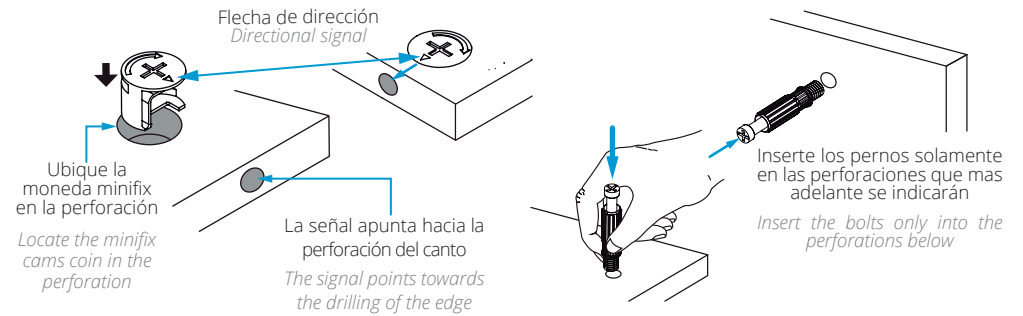

Ajustes de partes

Parts adjustments

¿Cuánto debe girar una tuerca?
How much should a screw turn?

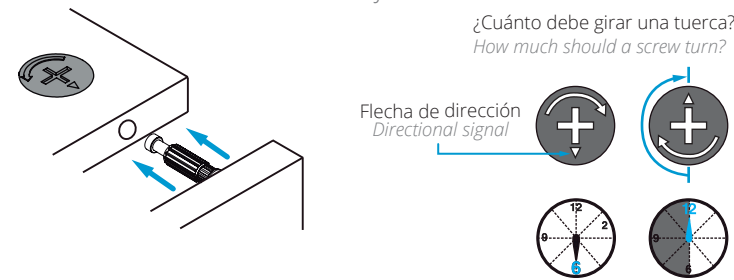

Tarugos Wooden pins

Introduzca los tarugos solo hasta su tope máximo
Insert the wooden pins only up to their maximum peak

Inserte los tarugos solamente en las perforaciones que más adelante se indicarán
Insert the wooden pins only into the perforations below

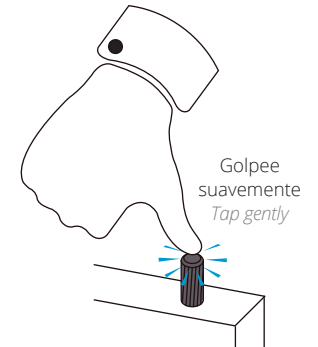

2. Preparación de las partes

Preparation of the parts

Para este paso necesitarás:

For this step you will need:

Herramientas

Tools

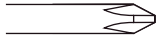

Destornillador de estrella
Star screwdriver

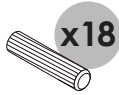

Tarugos
Wooden pins

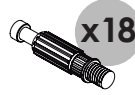

Pernos Minifix
Spreading bolt



Minifix
Minifix cams

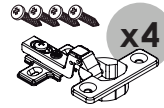

Bisagras internas
Internal hinges

Herrajes

Fittings

IMPORTANTE:

Antes de iniciar el pre ensamblaje, separar el riel cuidadosamente, que consta de dos partes (**1 y 2**). Para separar, presione la palanca hacia abajo como indica la imagen 1.

IMPORTANT:

Before starting the pre assembly, separate the slides carefully, the slides are made of two parts (**1 and 2**). To separate them, press the lever down as shown in image 1

Imagen 1

Image 1

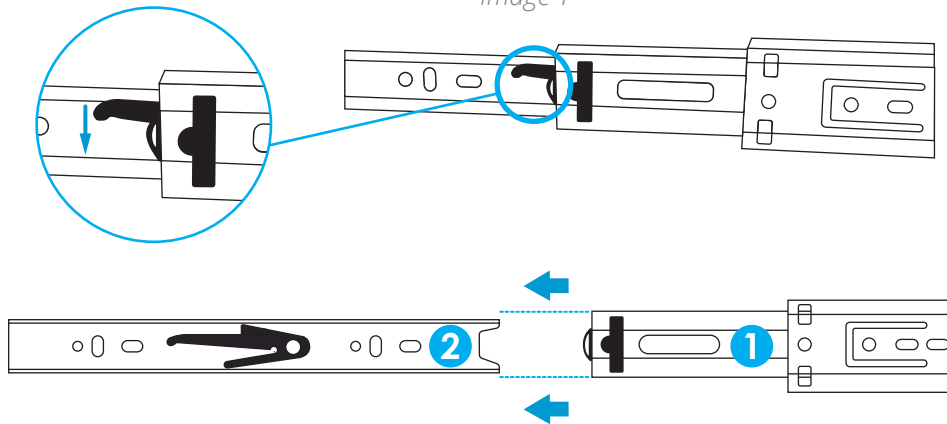

1

NOTA: El riel parte 1 se fija en los laterales del mueble D y E.

Note: Slide part 1 is assembled on the sides of part D and E.

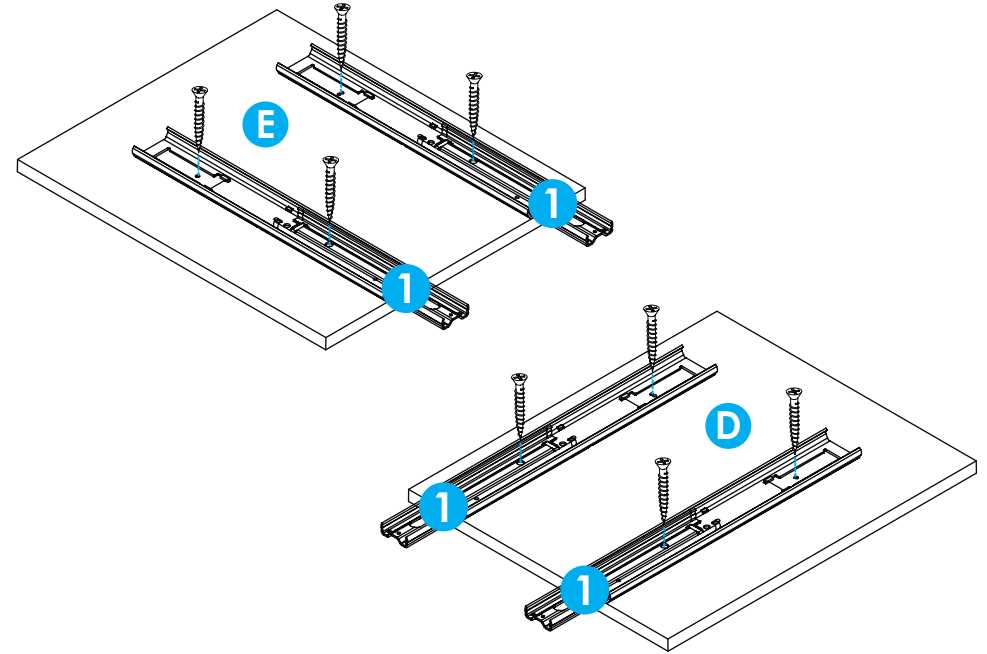

2

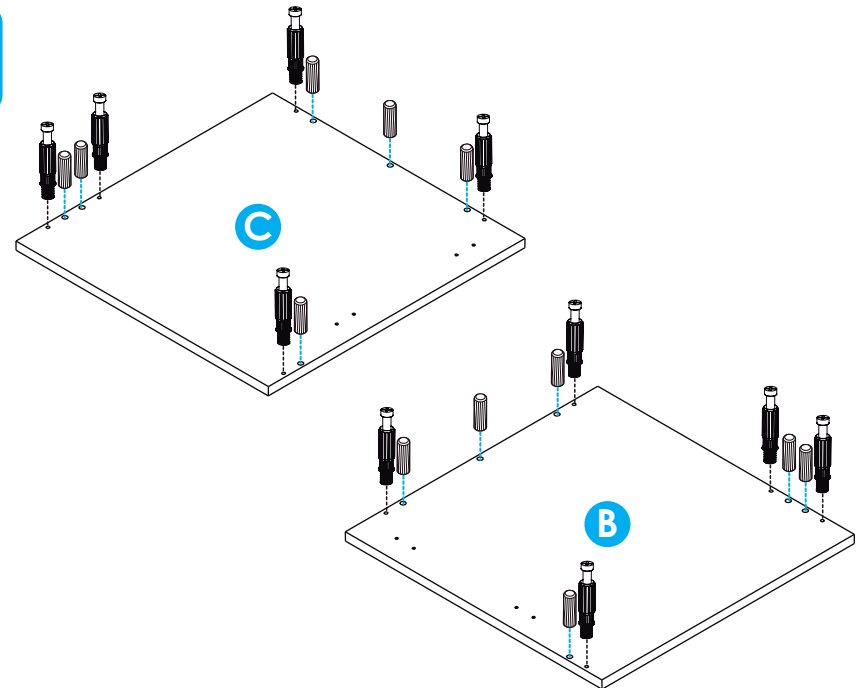

3

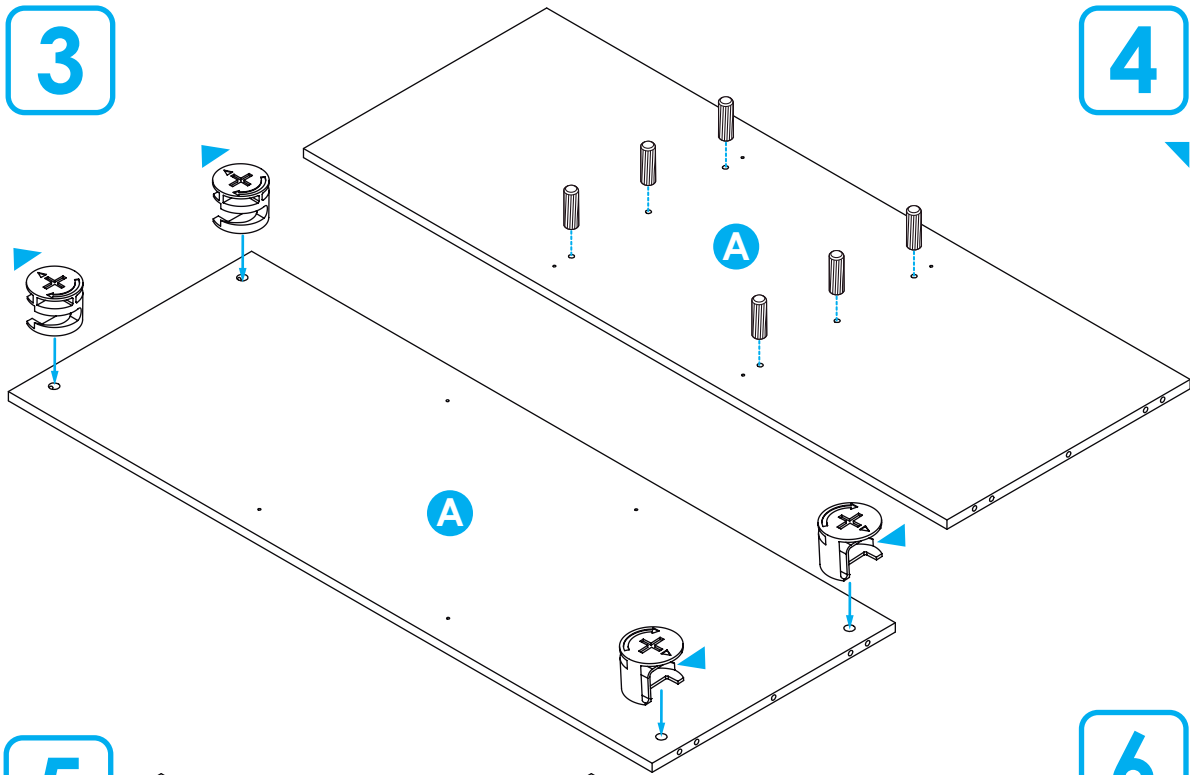

4

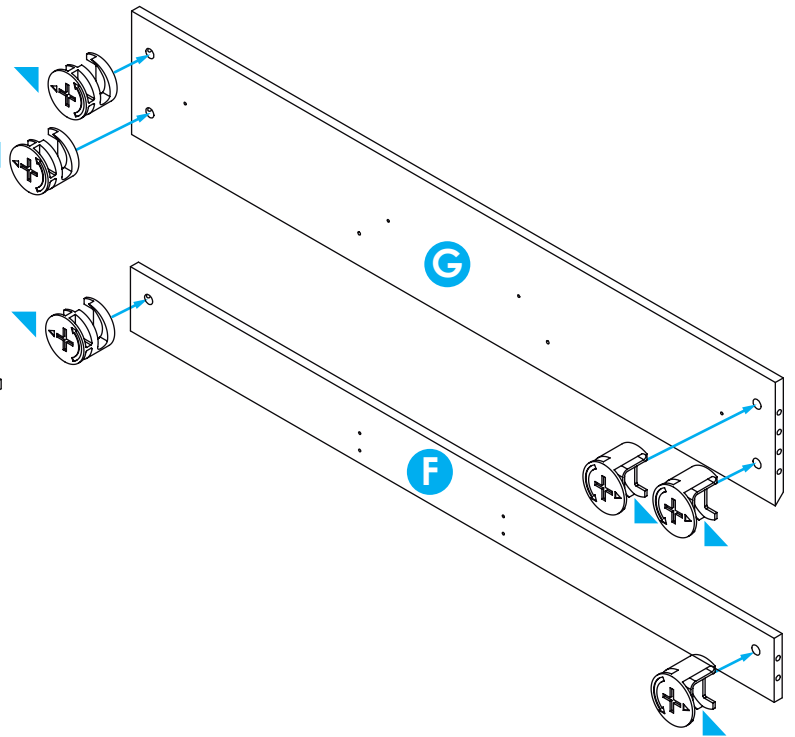

5

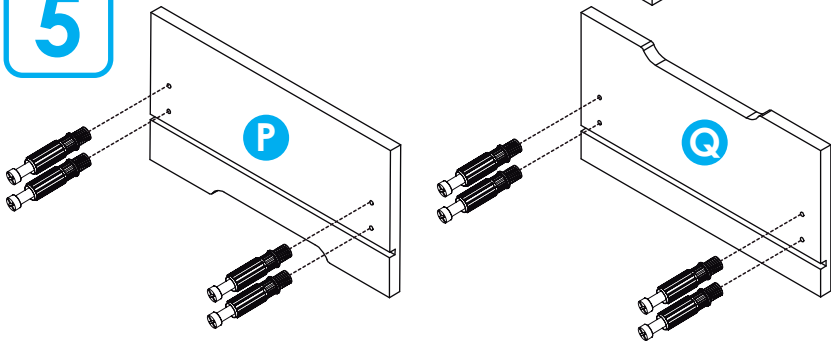

6

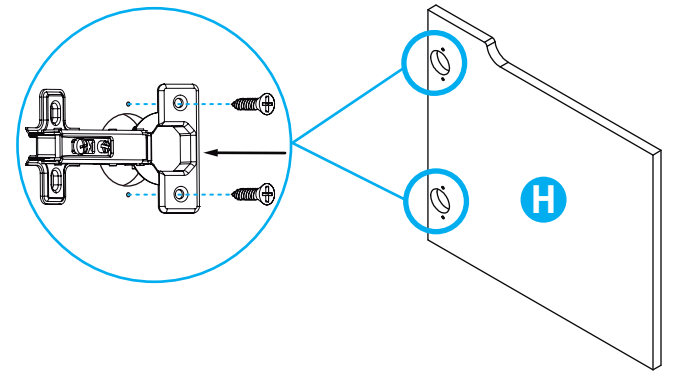

7

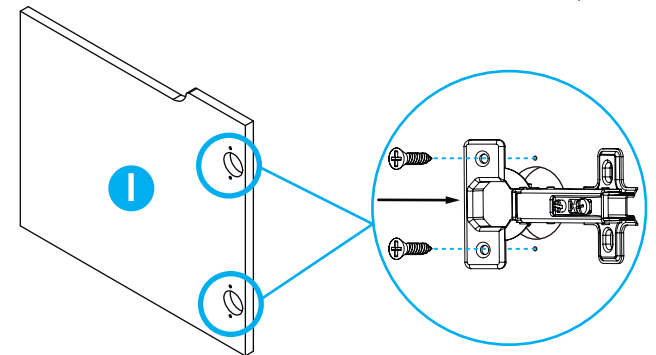
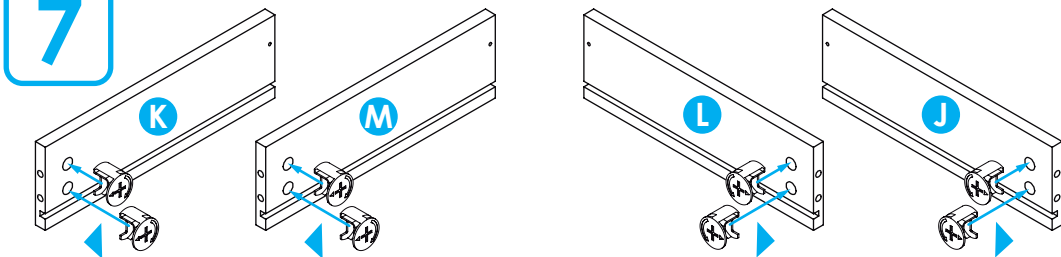

3. Preparación para ensamblar

Assembly steps



Se recomienda armar el mueble sobre la caja o una superficie lisa para no rayarlo.

Is recommended to assemble the product top of the box or on a flat surface to not scratch it.

Para este paso necesitarás:
For this step you will need:

Herramientas

Tools



Herrajes

Hardware

x10

Tornillos ensamble 2"
Assembly screws 2"

x4

Riel full extensión liviano
Lightweight full extension
rail

x4

Tornillos ensamble 1"
Assembly screws 1"

1

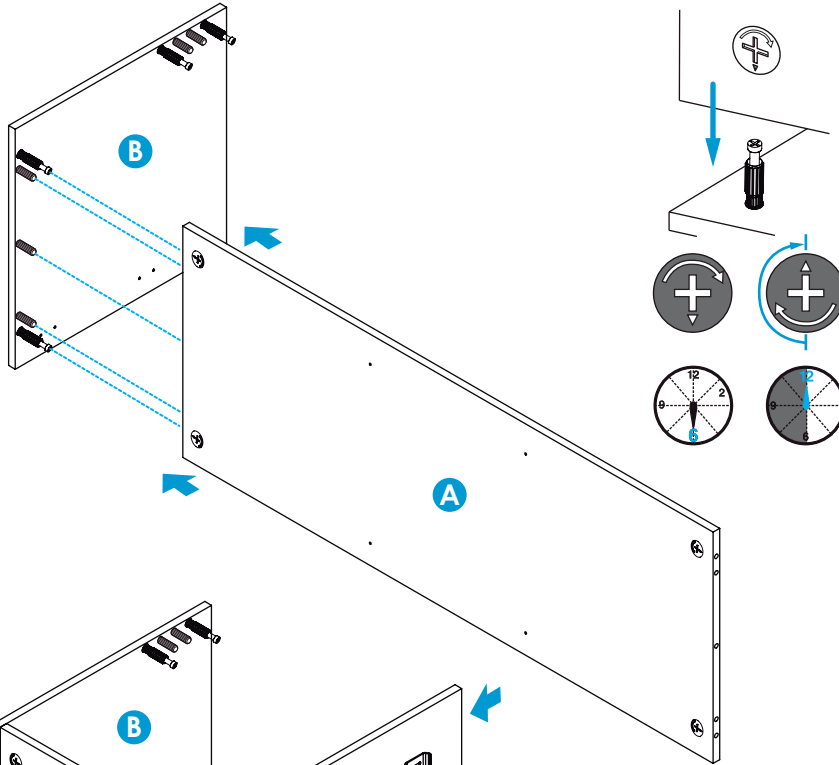

2

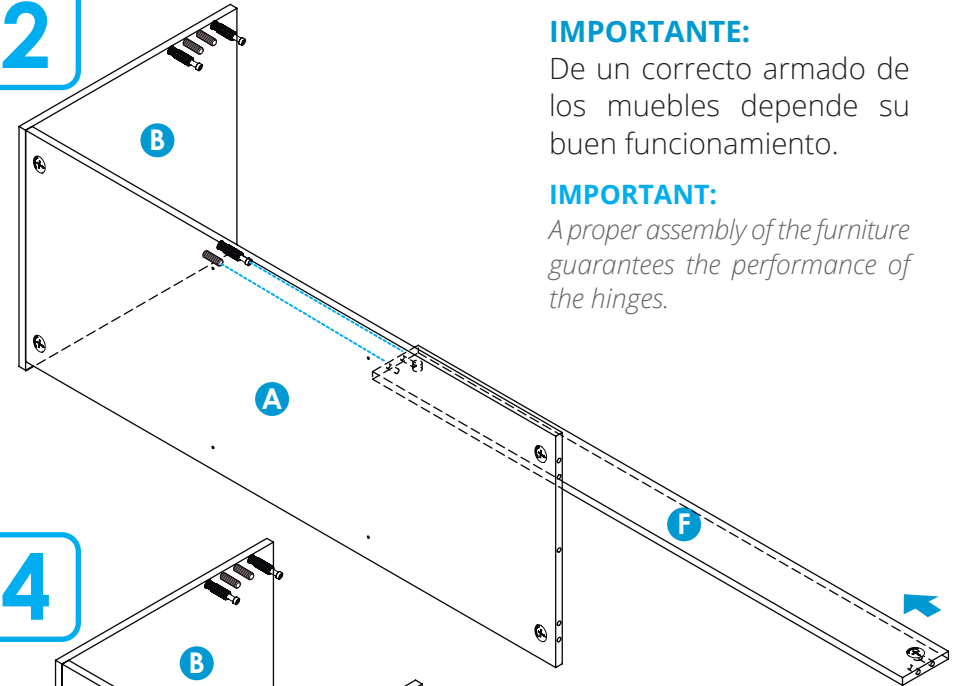

IMPORTANTE:

De un correcto armado de los muebles depende su buen funcionamiento.

IMPORTANT:

A proper assembly of the furniture guarantees the performance of the hinges.

3

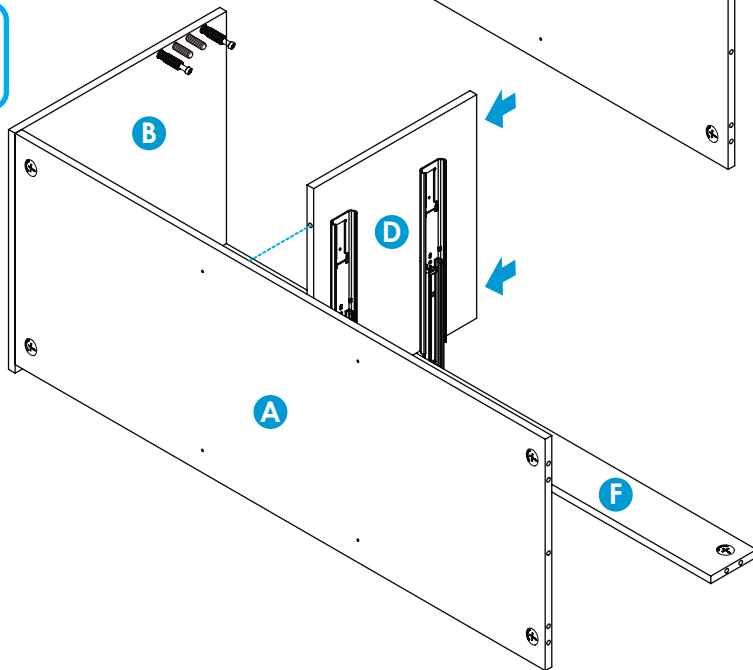

4

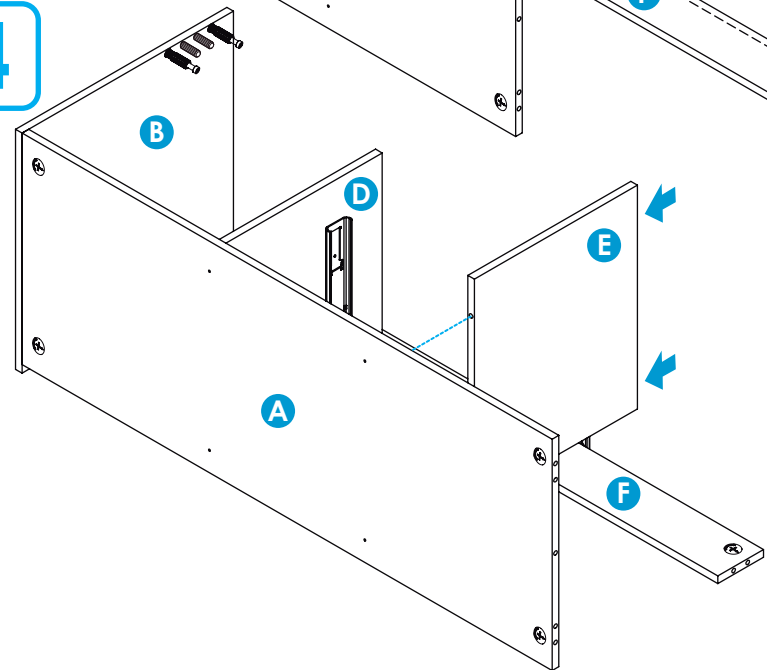

5

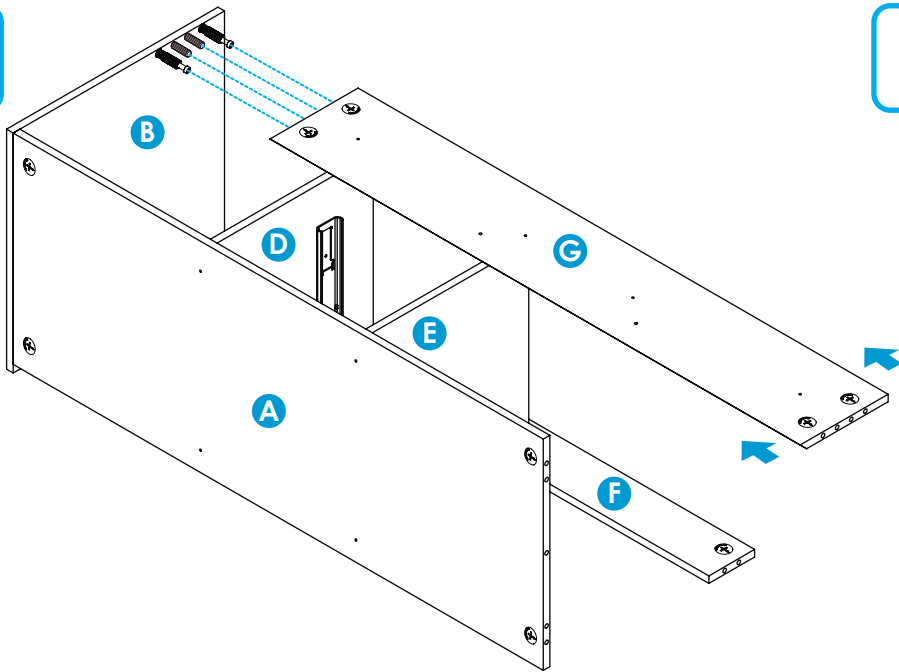

6

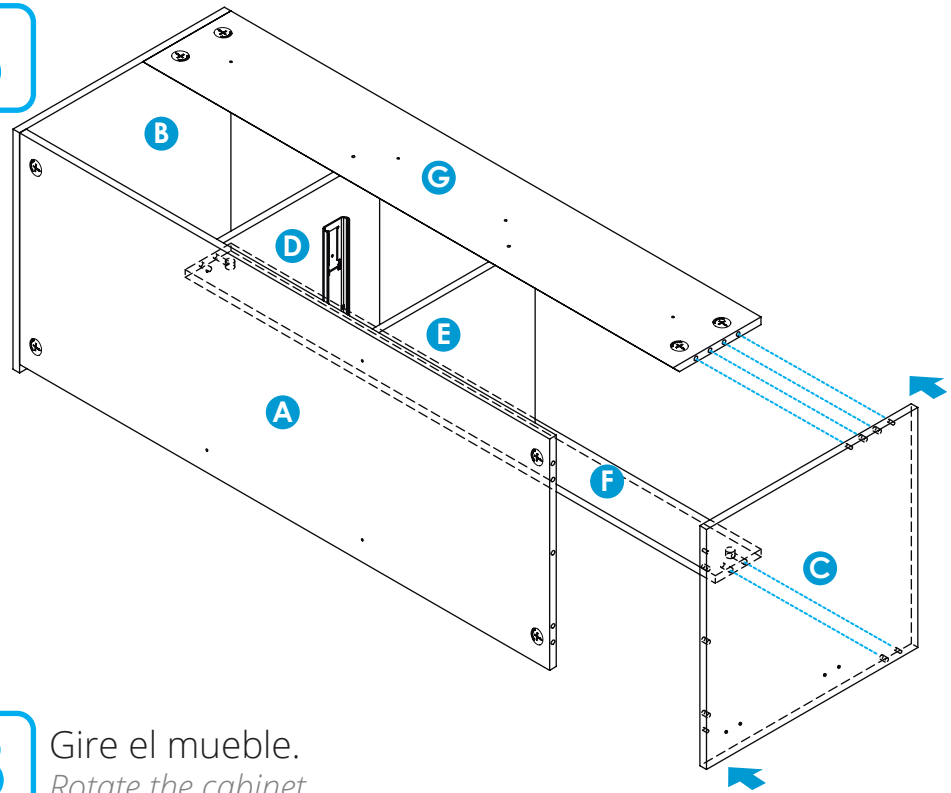

7

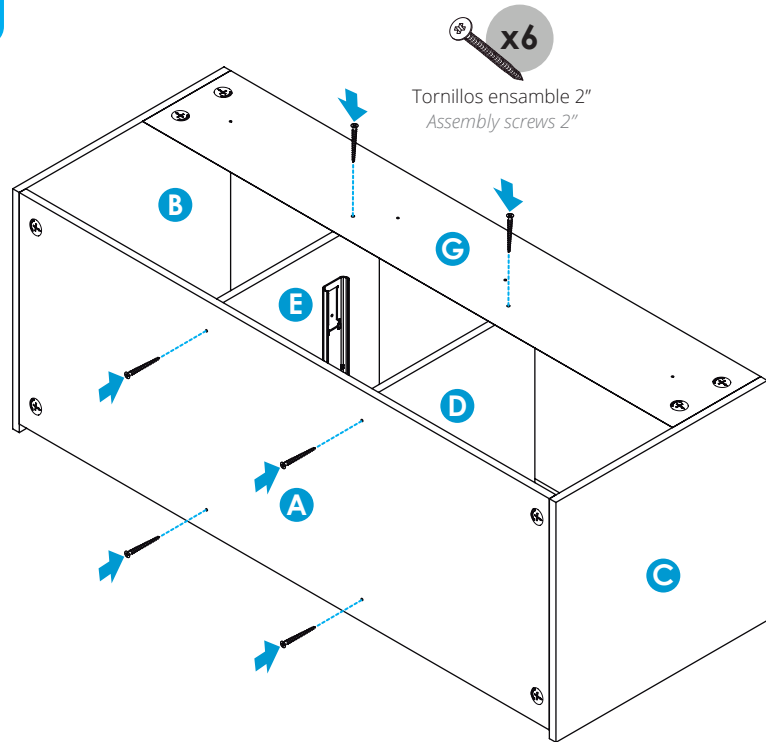

x6
Tornillos ensamble 2"
Assembly screws 2"

8

Gire el mueble.
Rotate the cabinet.

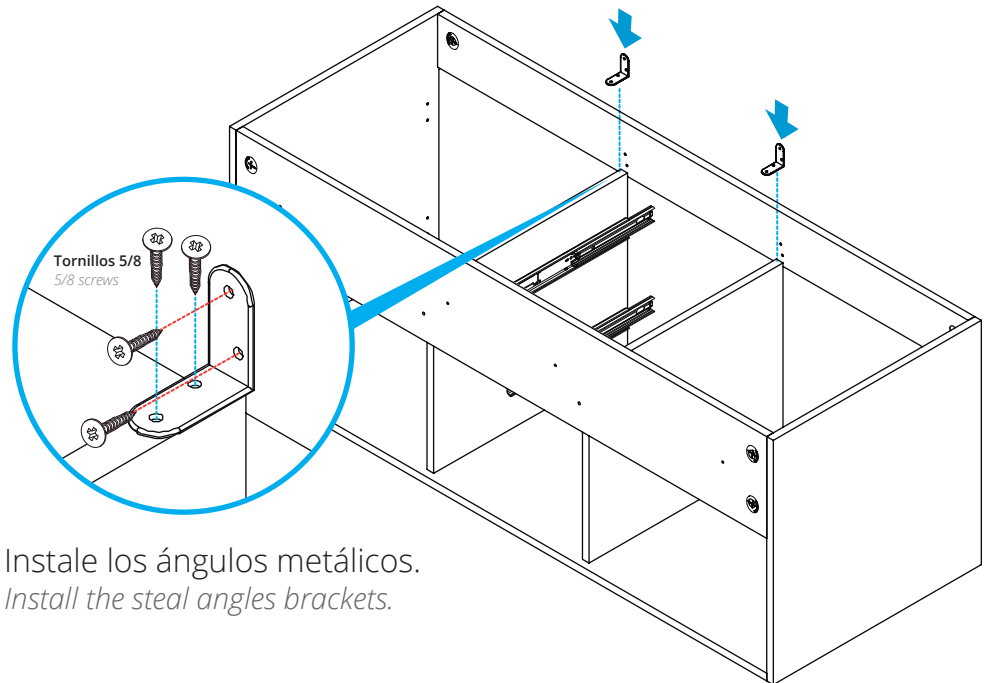

Instale los ángulos metálicos.
Install the steel angles brackets.

9 Ensamble cajón superior.
Assemble upper drawer.

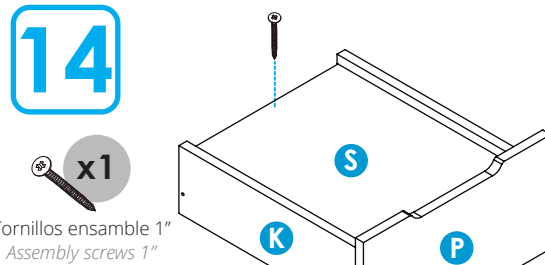
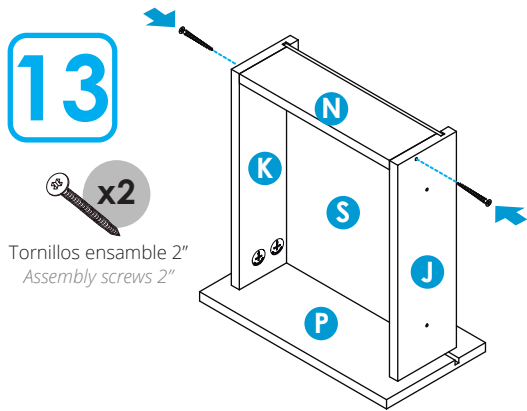
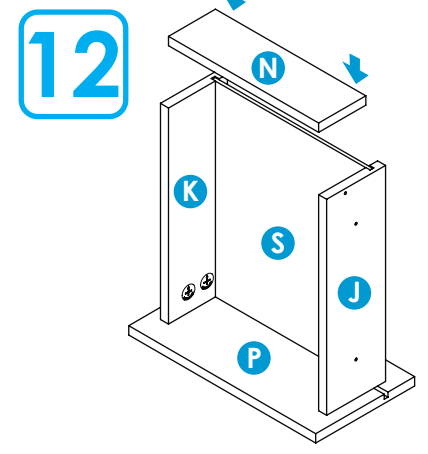
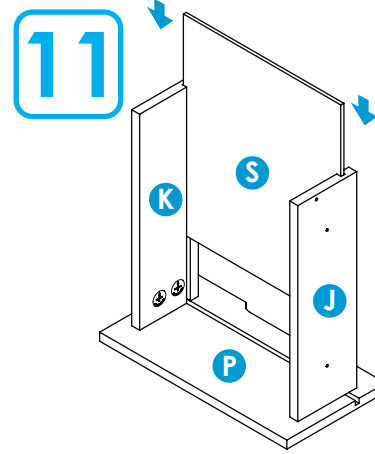
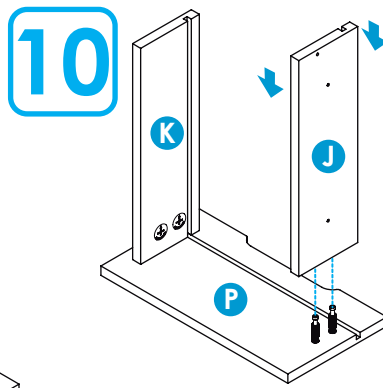
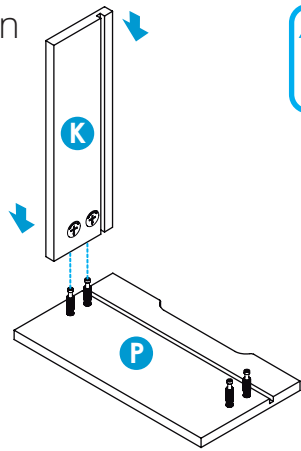

15 **NOTA:** El riel parte 2 se fija en los laterales del mueble K y J.
Note: Slide part 2 is assembled on the sides of part K and J.

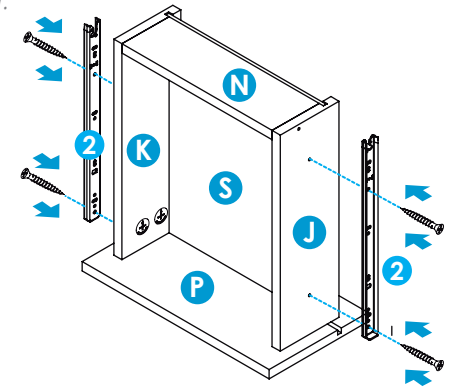

16 Ensamble cajón inferior.
Assemble lower drawer.

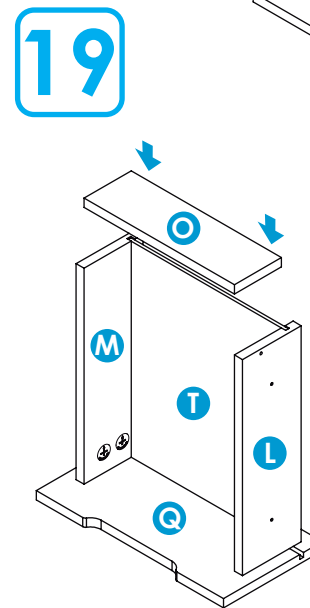
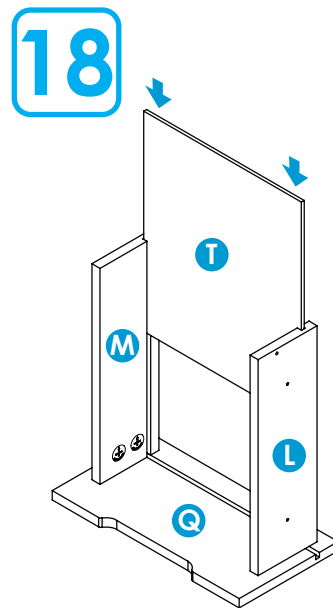
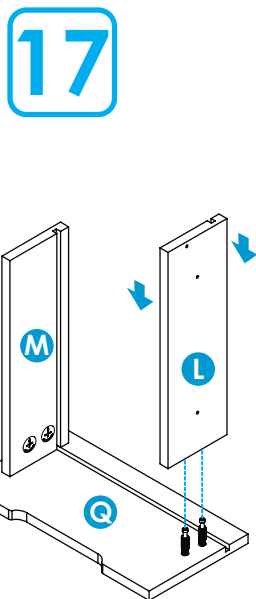
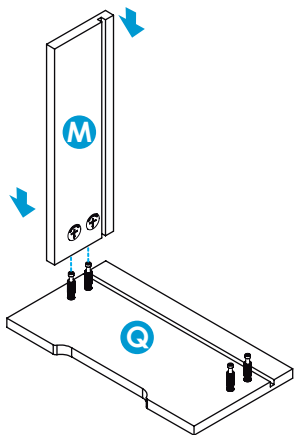

20

x2
Tornillos ensamble 2"
Assembly screws 2"

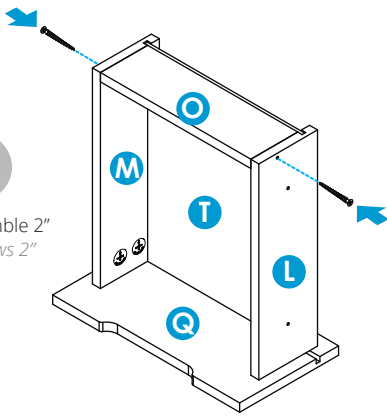
**21**

x1
Tornillos ensamble 1"
Assembly screws 1"

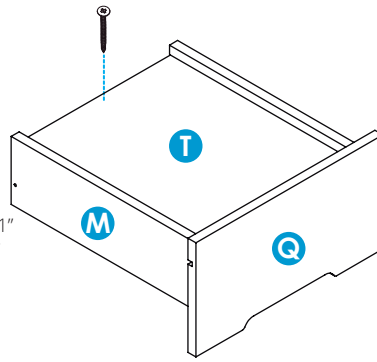
**22**

NOTA: El riel **2** se fija en los laterales del mueble **L** y **M**.
Note: Slide part **2** is assembled on the sides of part **L** and **M**.

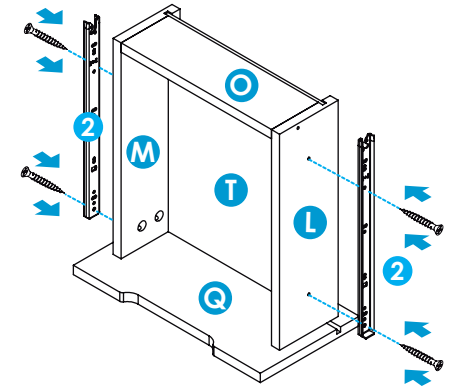
**23**

Cajón superior.
Upper drawer.

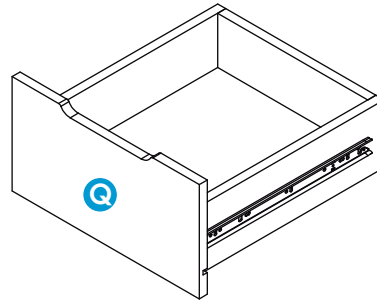
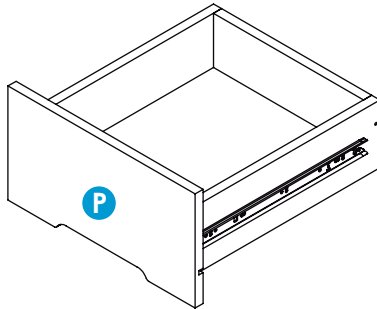

Cajón inferior
Lower drawer.

24

A. Para instalar la puerta al mueble se ensamblará las bisagras.
A. To install the door to the furniture, the hinges.

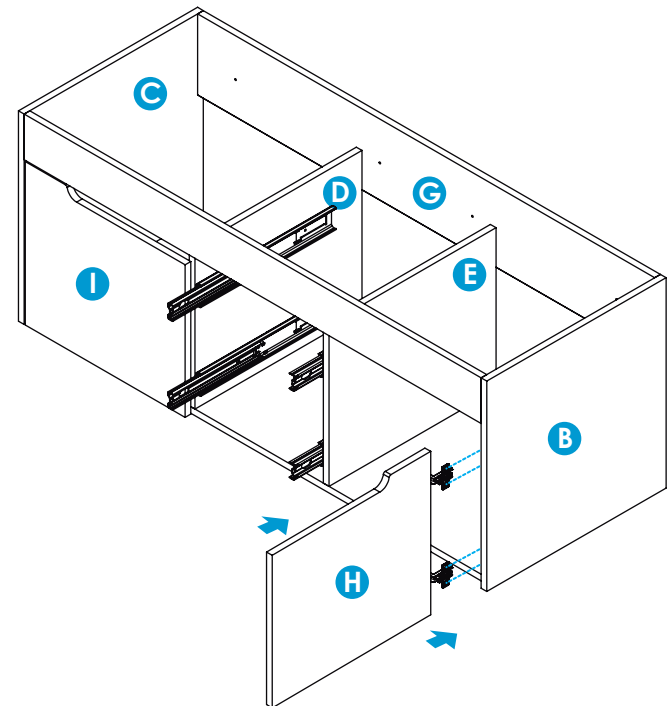
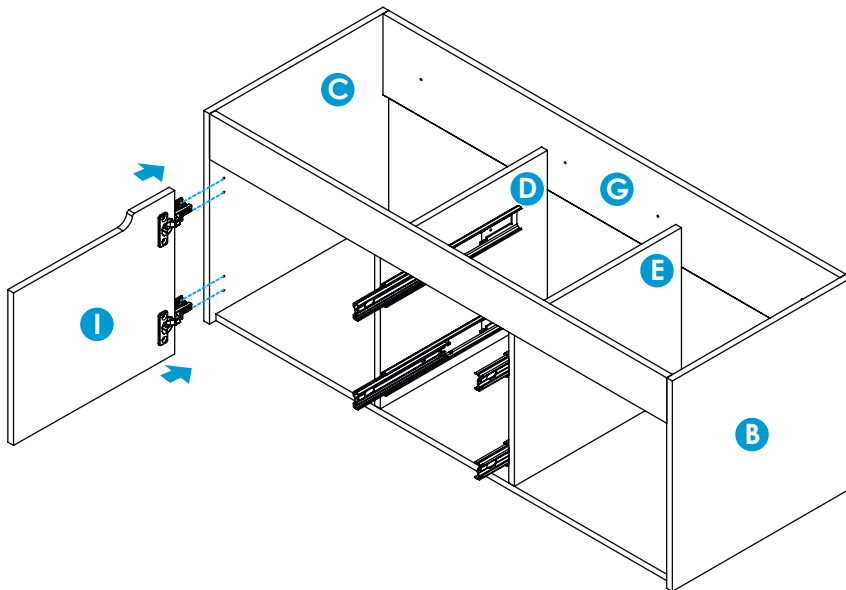

B. Nivelar: Para nivelar las puertas cuadrándolas al nivel deseado, afloje el tornillo de la bisagra, como lo muestra el detalle. Cuando esté en el lugar indicado, asegure los tornillos bisagra.

B. Level: To level the doors, to meet the desired level, loosen the hinge screw, as shown in detail. When in the right place, secure the hinge screws.

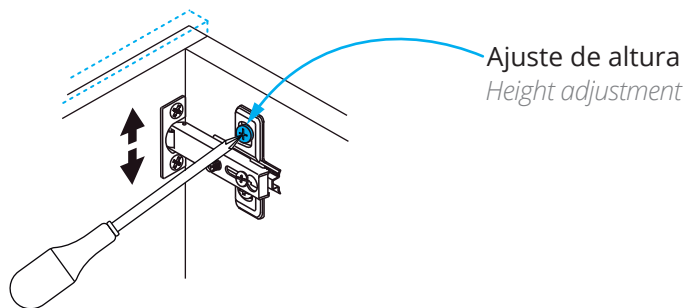

C. Ajuste de profundidad: le permite llevar las puertas hacia dentro o hacia afuera, aflojando el tornillo de la bisagra, como lo muestra el detalle.

C. Depth adjustment: allows you to move the doors in or out, loosening the hinge screw as shown in detail.

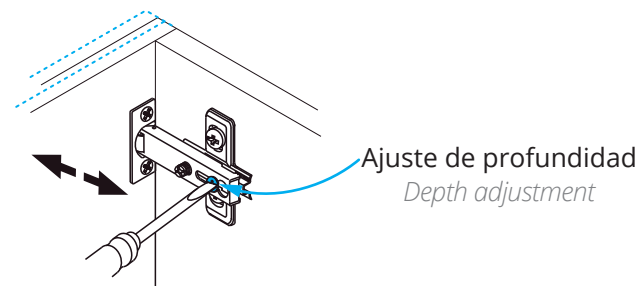

D. Ajuste lateral: le permite llevar las puertas hacia la derecha o la izquierda, nivelándola con los laterales aflojando o apretando el tornillo de la bisagra como lo muestra el detalle.

D. Side adjustment: Allows you to move the doors to the right or left, leveling with the sides loosening or tightening the hinge screw as shown by the detail.

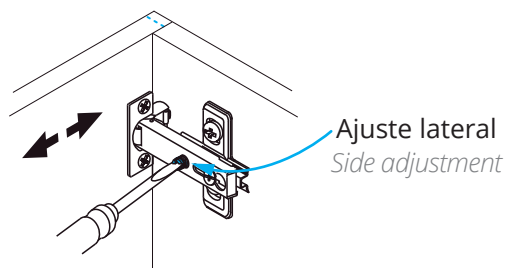

25

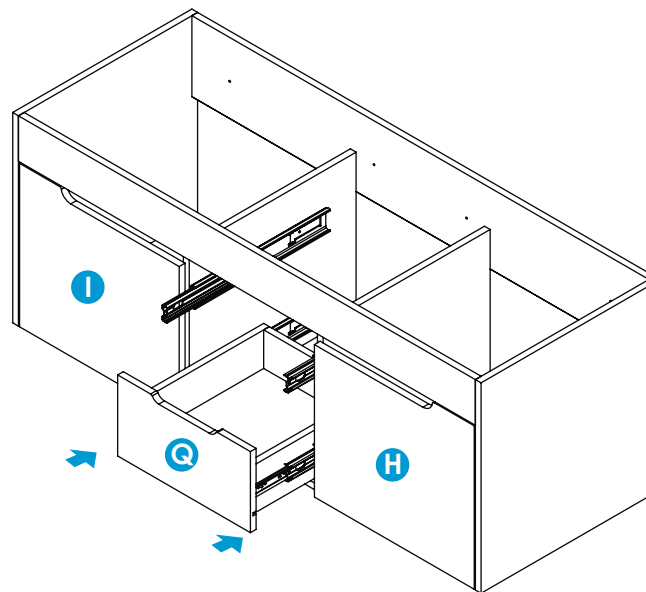

26

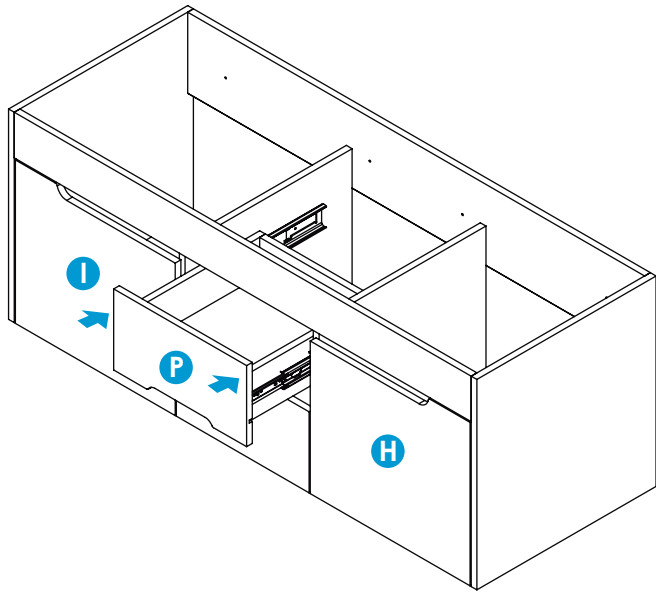

Instalación anclaje con cuña

Wall wedge installation

A Identifique la posición correcta del anclaje con cuña, para que éste pueda ser instalado de manera adecuada en la pared.

Identify the correct position of the wall wedge, so that it can be properly installed on the wall.

Posición correcta
Correct position



Posición correcta
Correct position

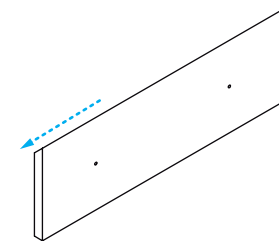
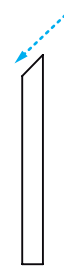

27

Montaje del mueble a pared: Para este paso necesitarás.

Wall-mounting cabinet: For this step you will need.

Herramientas

Tools



Regla niveladora
Level ruler

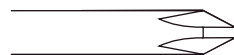

Destornillador de estrella
Star screwdriver

Herrajes

Fittings



Tornillos chazo 2"
Ramplug screws 2"



Chazos 2"
Ramplug 2"

Posiciones incorrectas

Wrong positions

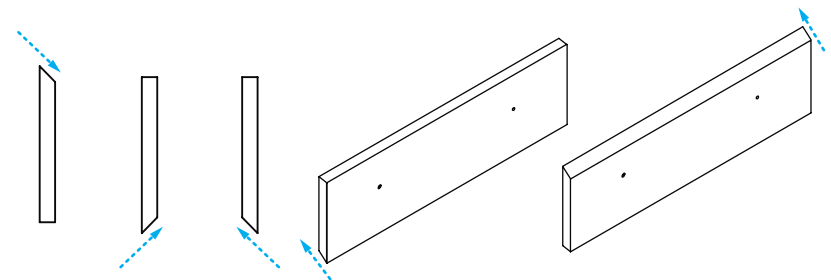

B Mida 51 cm desde el piso hacia arriba, marque el punto final e instale allí el anclaje con cuña con la ayuda de una regla niveladora.

Measure 51 cm from the floor up, mark the end point and install the wall wedge there using a leveling ruler.

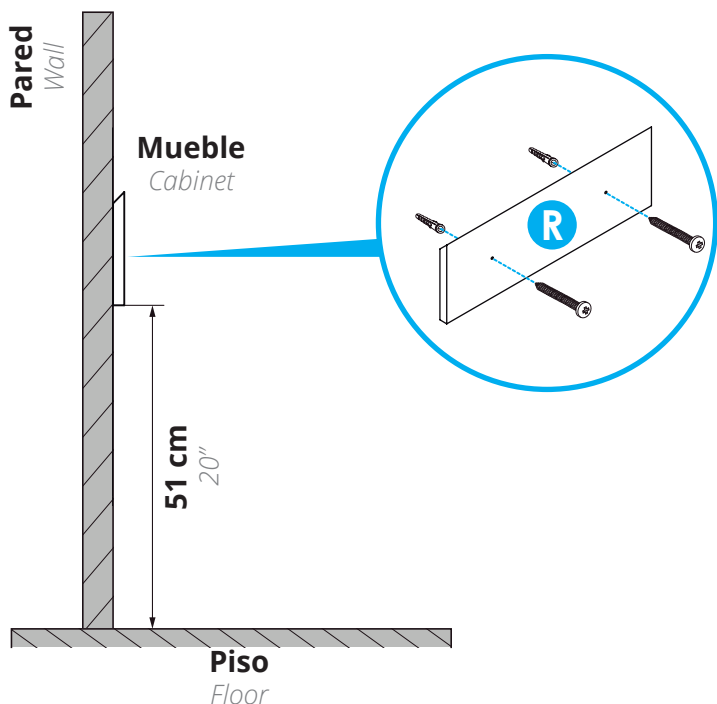

IMPORTANTE:

Tenga en cuenta que las paredes deben ser sólidas, de cemento / ladrillo. Si va a instalar el mueble sobre paredes de Drywall (paredes secas), debe utilizar chazos y tornillo de expansión metálico especial para drywall.

IMPORTANT:

note that the walls must be solid, cement / brick. In case of drywall installation, change the ramplug for a drywall metallic Spring Toggle.

C **Para fijar el mueble:** Perfore la pared a la altura indicada en las perforaciones ubicadas en el refuerzo trasero del mueble con ayuda de una broca para pared (tungsteno) 3/8", descargue el mueble, luego introduzca los chazos plásticos, monte el mueble nuevamente y asegúrelo con tornillos chazos.

To secure the cabinet: drill the wall at the indicated height of the perforations with the help of a 3/8" wall bit (tungsten), then insert the plastic slab and secure the furniture with screws.

Herramientas

Tools



Destornillador de estrella
Star screwdriver

Herrajes

Fittings



Tornillos chazo 2"
Ramplug screws 2"

Chazos 2"
Ramplug 2"

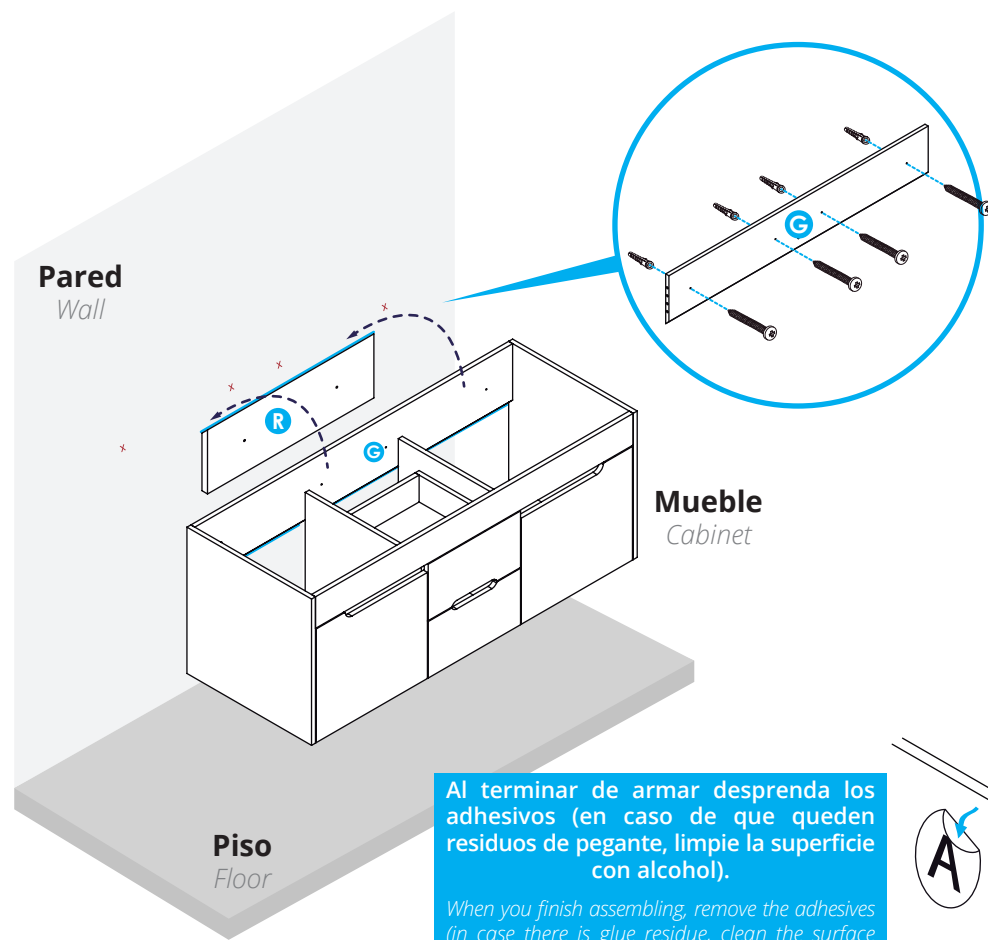

Al terminar de armar despegue los adhesivos (en caso de que queden residuos de pegante, limpie la superficie con alcohol).

When you finish assembling, remove the adhesives (in case there is glue residue, clean the surface with alcohol).

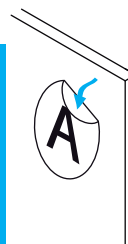

4. Cuidados y mantenimiento

Care and maintenance

Cuidados y mantenimiento para los muebles

- Para limpiar el mueble use un trapo seco o humedézcalo en agua y detergente suave, elimine el exceso de agua.
- No pinte ni barnice el mueble.
- No esponga el mueble a la intemperie.
- Evite arrastrarlo, puede ocasionar daños en la estructura.
- Por seguridad, evite que los menores jueguen con el mueble.
- No esponga el mueble a funciones diferentes para lo que fueron diseñados. Ejemplo: sentarse en el mueble.

Care and maintenance for cabinet

- To clean the cabinet, use a dry cloth or moisten it in water and mild detergent.
- Do not paint or varnish the furniture.
- Do not expose the furniture to the out side.
- Avoid dragging it, it can cause damage to the structure.
- For safety, avoid children playing with the furniture.
- Do not expose the furniture to different functions for which they were not designed. Example: sit on the furniture.



www.firplak.com

Sede principal: Calle 29 N° 41-15 (Itagüí - Antioquia), Teléfono: (574) 444 17 71

Si necesita ayuda comuníquese con su asesor comercial firplak tel: 4441771 (ext: 108). tel: 4441771 (ext: 131)

if you need help, contact your business advisor firplak tel: 4441771 (ext: 131)