

# INSTRUCCIONES DE ENSAMBLE

## ASSEMBLY INSTRUCTIONS



**\* Instrucciones de Instalación:** Mueble superior cocina Ambar 180 / mueble para cocina  
*Installation Instructions: UPPER CABINET AMBAR 70.8 / Kitchen cabinet*

### RECOMENDACIONES PREVIAS / Previous recommendations:



Si las paredes donde va a ubicar el mueble son en drywall, debe adquirir chazos y tornillos especiales para su instalación.

*If the walls where you are locating the cabinet are in drywall, you must purchase special ramplug and screws for installation.*



No golpee ni martille todo el mueble, sólo donde se le indica.

*Do not strike or hammer all the cabinet, only where directed.*



No pinte ni barnice el mueble.

*Do not paint or varnish the cabinet.*



No arrastre ni se suba al mueble, si necesita moverlo por favor levántelo.

*Do not drag or stand on the cabinet, if you need to move it please lift up.*



Lea detenidamente y siga en orden consecutivo las instrucciones de armado.

*Read carefully and follow in sequence the assembly instructions.*



No expongas el mueble a la intemperie, ni al calor.

*Do not expose the cabinet to the outdoors or the heat.*

### IMPORTANTE:

Antes de empezar a ensamblar el mueble, lea detenidamente las instrucciones. Pre-ensamble el mueble sobre su caja, para no rayarlos. Si falta una parte o piensa que esta defectuosa no devuelva el mueble al almacén; le agradecemos llamar al (5-74) 444 17 71, o comuníquese con su asesor principal, también nos pueden escribir a [servicioalcliente@firplak.com](mailto:servicioalcliente@firplak.com).

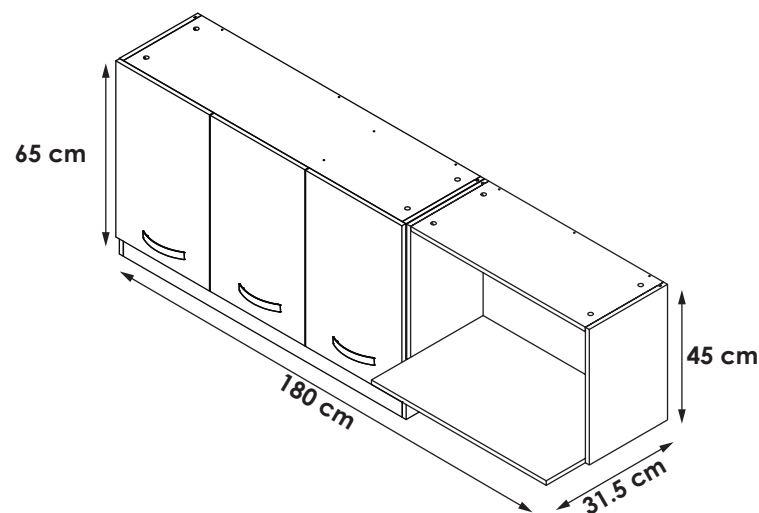

### Sello de calidad / Quality seal

**Por favor no deseche el instructivo del mueble, este le servirá para cualquier reclamo con respecto a la garantía del mismo.**

*Please do not discard the cabinet's instructions, it will serve you for any claim regarding its warranty.*



**IMPORTANT:** Before you start to assemble the cabinet, please read the instructions. Pre assembly the cabinet on its box, to prevent scratches. If a part is missing or damaged, do not return the furniture to the store, please call the (5-74) 444 17 71 or contact your sales assistant. also you can write to [servicioalcliente@firplak.com](mailto:servicioalcliente@firplak.com).

# 1. Identificación de las partes

## Parts identification

### HERRAMIENTAS REQUERIDAS / Tools required :

\* No incluido.  
Not included.

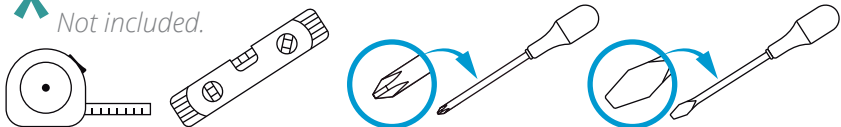

### A Muebles superiores cocina. Kitchen cabinet



Tabla de piezas  
Parts Chart

Pieza / Part	Cantidad / Total
A	1
B	1
C	1
D	1
E	1
F	1
G	1
H	1
I	1
J	1
K	1
L	1
M	1
N	1
O	1
P	1
Q	1
R	1
S	1
T	1
Cantidad Total	Desde From hasta to
20	A R

### B Identificación de herrajes. Hardware identification

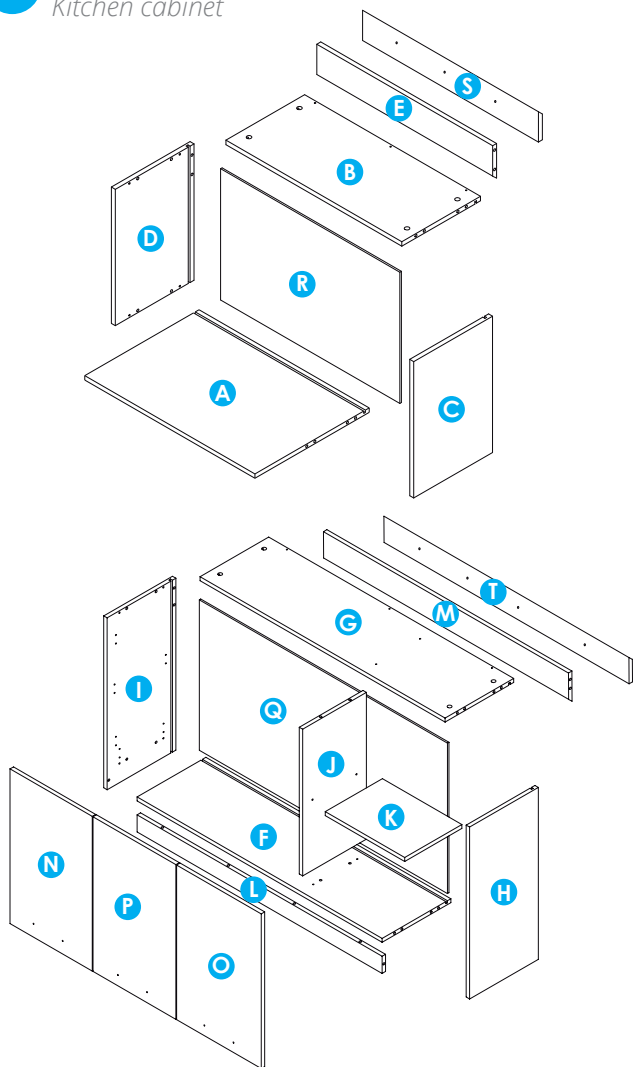

\* Tenga precaución al abrir la bolsa de herrajes de no perder ningún elemento. Compruebe si el contenido de las piezas es el correcto.

Be carefull opening the screw bag so you do not lose any. Chek if the number of screws is right.

### C Recomendaciones de ensambles. Assembly recommendations

#### Instalación de minifix y pernos de minifix Installing the minifix cams and spreading minifix

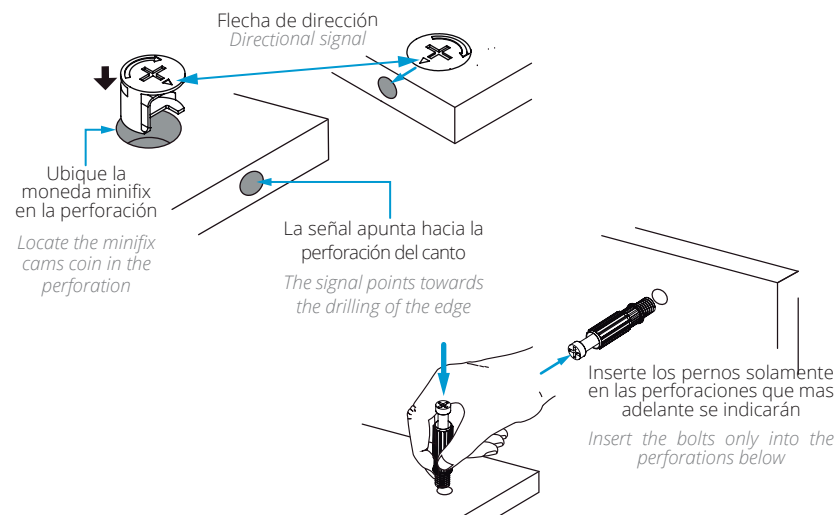

## Ajustes de partes

Parts adjustments

¿Cuánto debe girar una tuerca?  
How much should a screw turn?

Flecha de dirección  
Directional signal

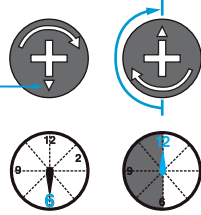

## Tarugos

Wooden pins

Introduzca los tarugos solo hasta su tope máximo  
Insert the wooden pins only up to their maximum peak

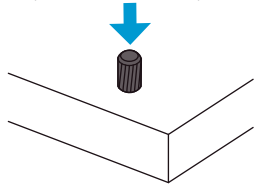

Inserte los tarugos solamente en las perforaciones que más adelante se indicarán  
Insert the wooden pins only into the perforations below

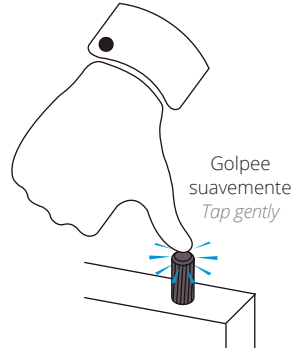
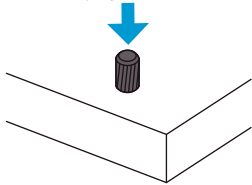

Golpee suavemente  
Tap gently

## 2. Preparación de las partes

Preparation of the parts

Se recomienda preparar las partes del mueble sobre la caja o una superficie lisa para no rayarlo.

*It is recommended to prepare the parts of the cabinet on the box or on a flat surface to not scratch it.*

Para este paso necesitarás:

*For this step you will need:*

### Herramientas

Tools

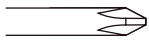

Destornillador de estrella  
Star screwdriver

### Herrajes

Fittings

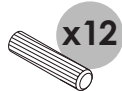

x12

Tarugos  
Wooden pins



x8

Pernos Minifix  
Spreading bolt



x8

Moneda Minifix  
Minifix cams

## Pre ensamble mueble microondas

Pre assembly microwave oven cabinet

1

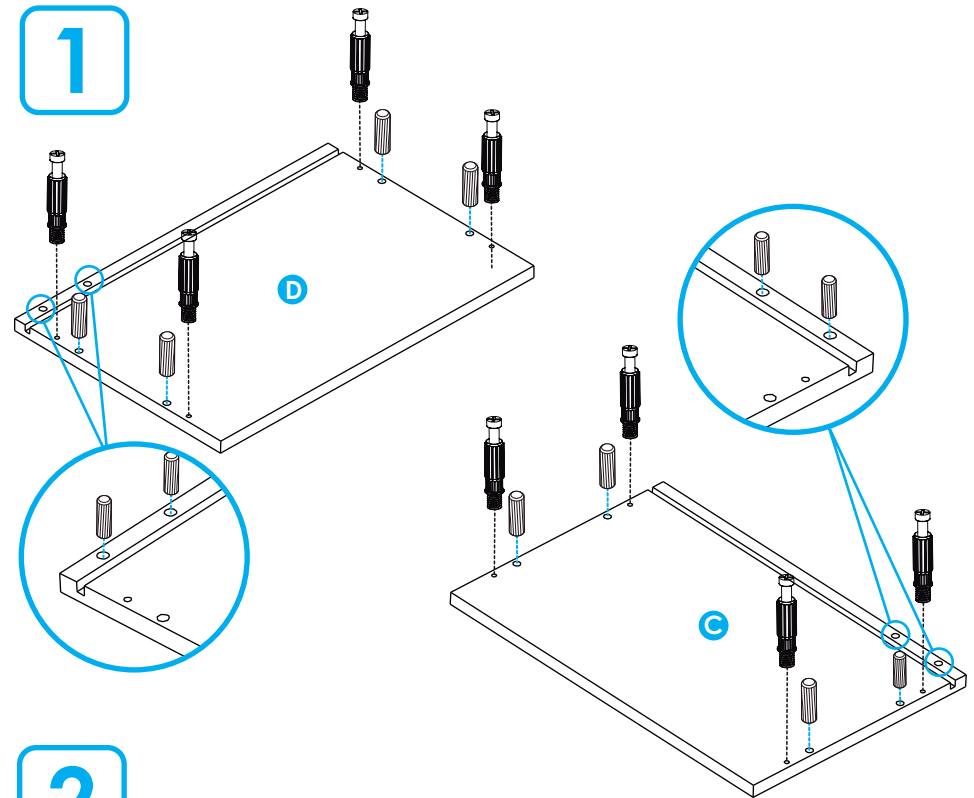

2

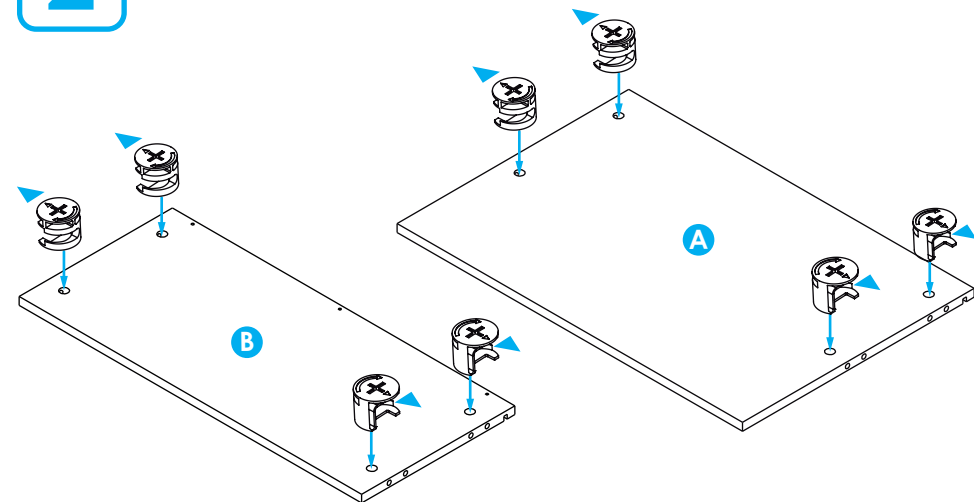

# Pre ensamble mueble locero

Pre assembly dish rack cabinet

## Herrajes Fittings



1

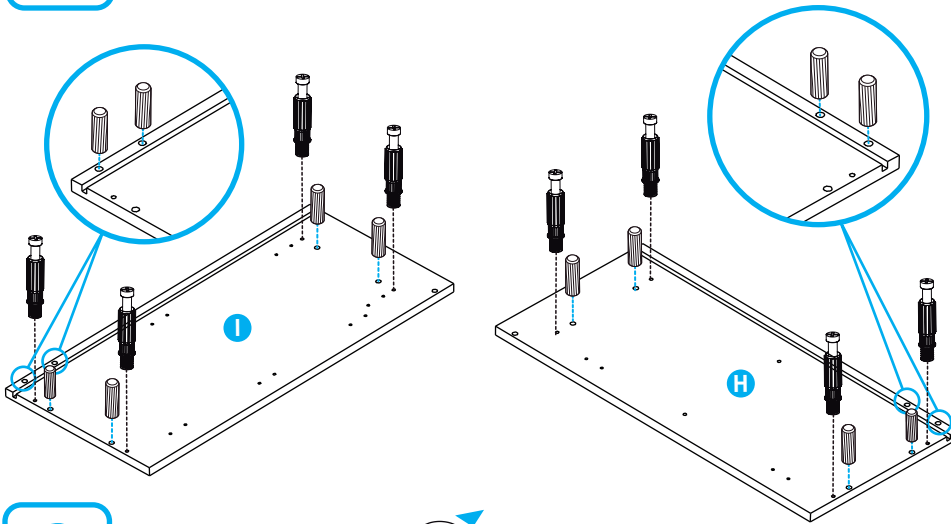

2

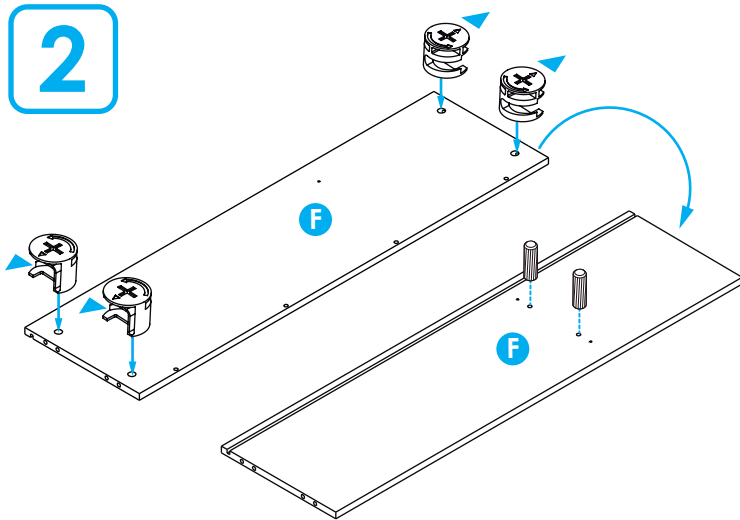

3

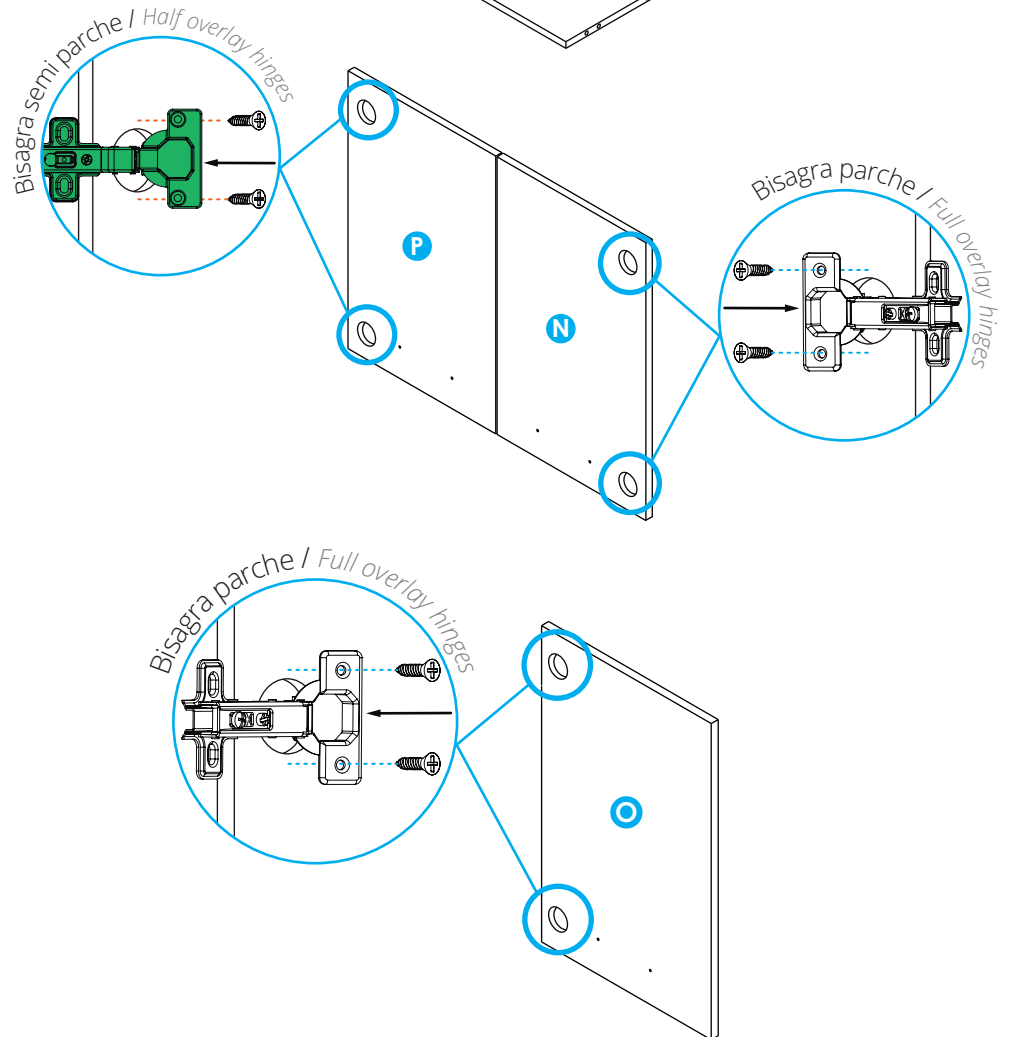

4

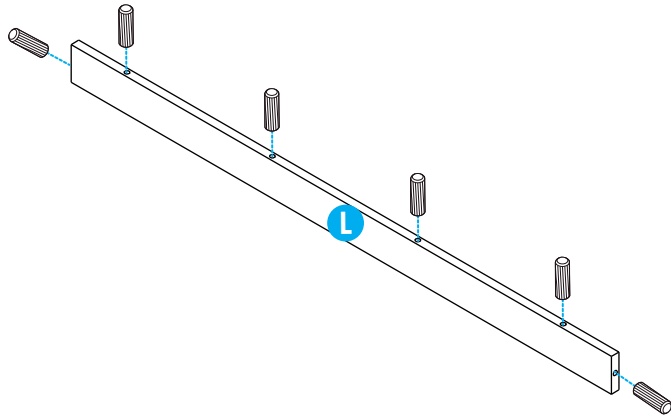

### 3. Preparación para ensamblar

#### Assembly steps

Se recomienda armar el mueble sobre la caja o una superficie lisa para no rayarlo.

*Is recommended to assemble the product top of the box or on a flat surface to not scratch it.*

Para este paso necesitarás:

*For this step you will need:*

#### Herramientas

*Tools*

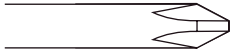

Destornillador de estrella  
*Star screwdriver*



Tornillos chazo 2"  
*Ramplug screws 2"*



Tornillos ensamble 2"  
*Assembly screws 2"*



Chazos 2"  
*Ramplug 2"*

#### Herrajes

*Hardware*

#### IMPORTANTE:

De un correcto armado de los muebles depende su buen funcionamiento.

#### IMPORTANT:

*A proper assembly of the furniture guarantees the performance of the hinges.*

## Ensamble mueble microondas

*Assembly microwave oven cabinet*

1

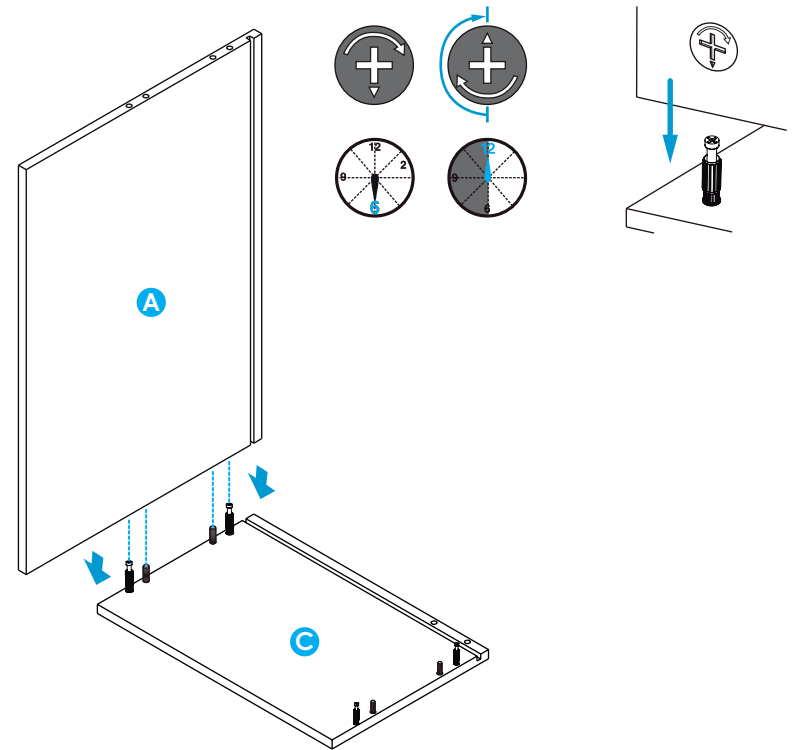

2

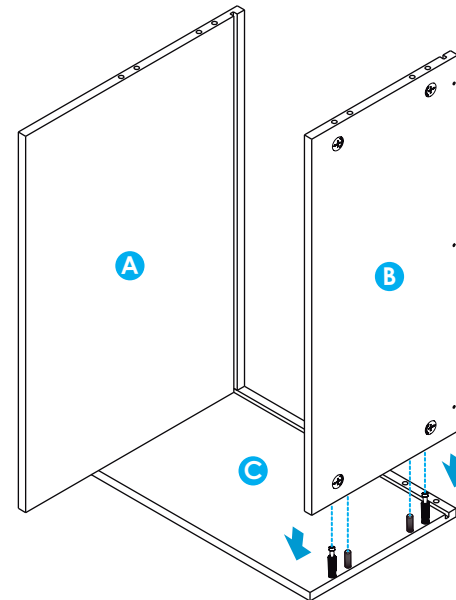

3

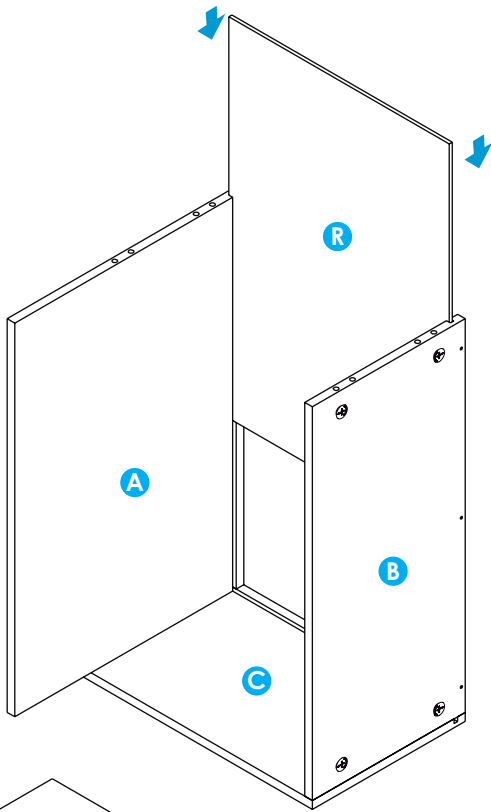

4

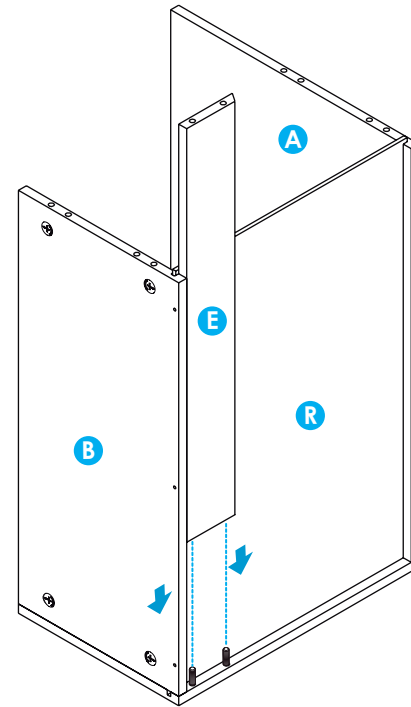

4

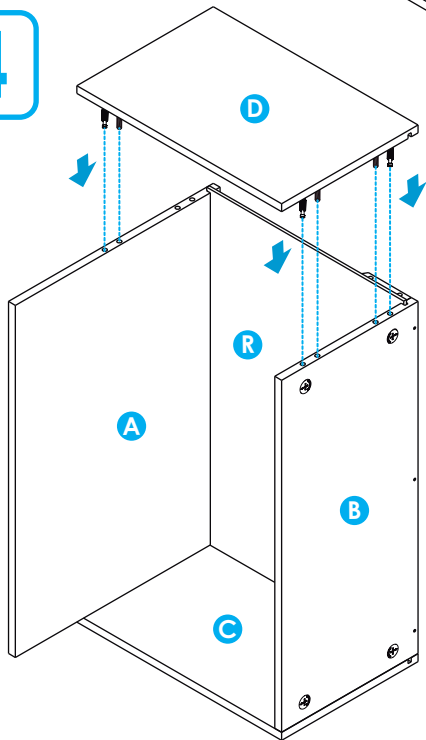

5

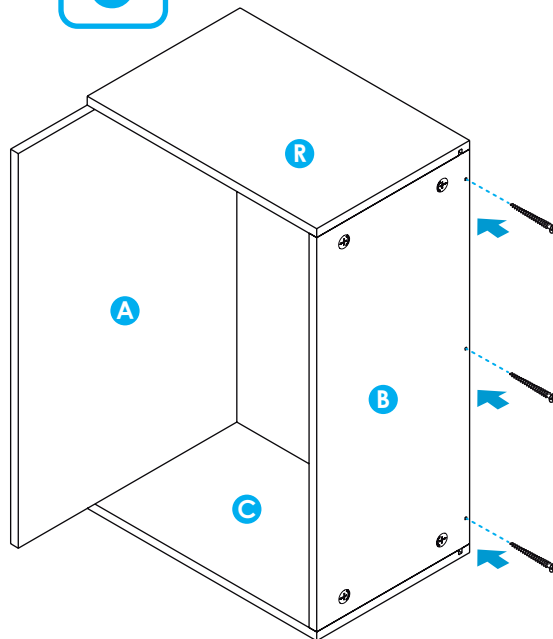

**Mueble armado completamente**  
*Fully assembled cabinet*

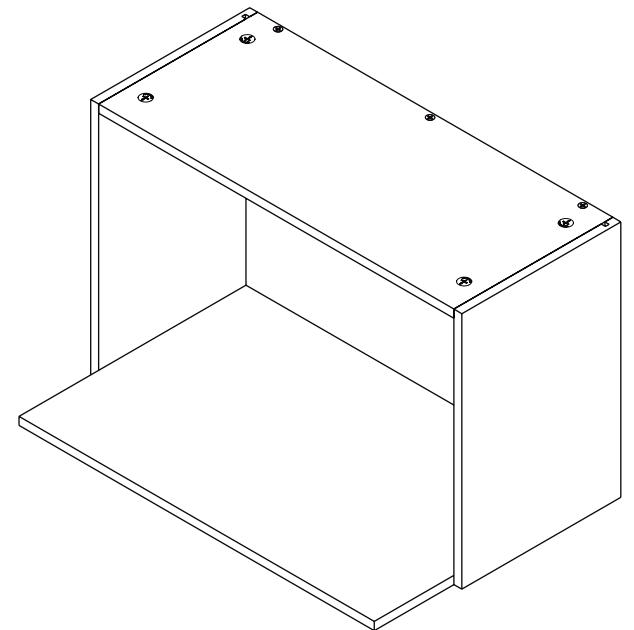

# Ensamble mueble locero

## Assembly dish rack cabinet

### Herramientas

Tools



Destornillador de estrella  
Star screwdriver



x4  
Soporte entepaño  
Shelf holder pins

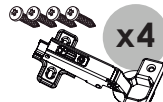

x4  
Bisagras parche  
Hinges

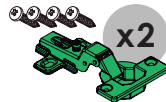

x2  
Bisagras semi parche  
Overlay hinges



x3  
manija  
Handle



x7  
Tornillos ensamble 2"  
Assembly screws 2"



x1  
Locero  
Dish rack

3

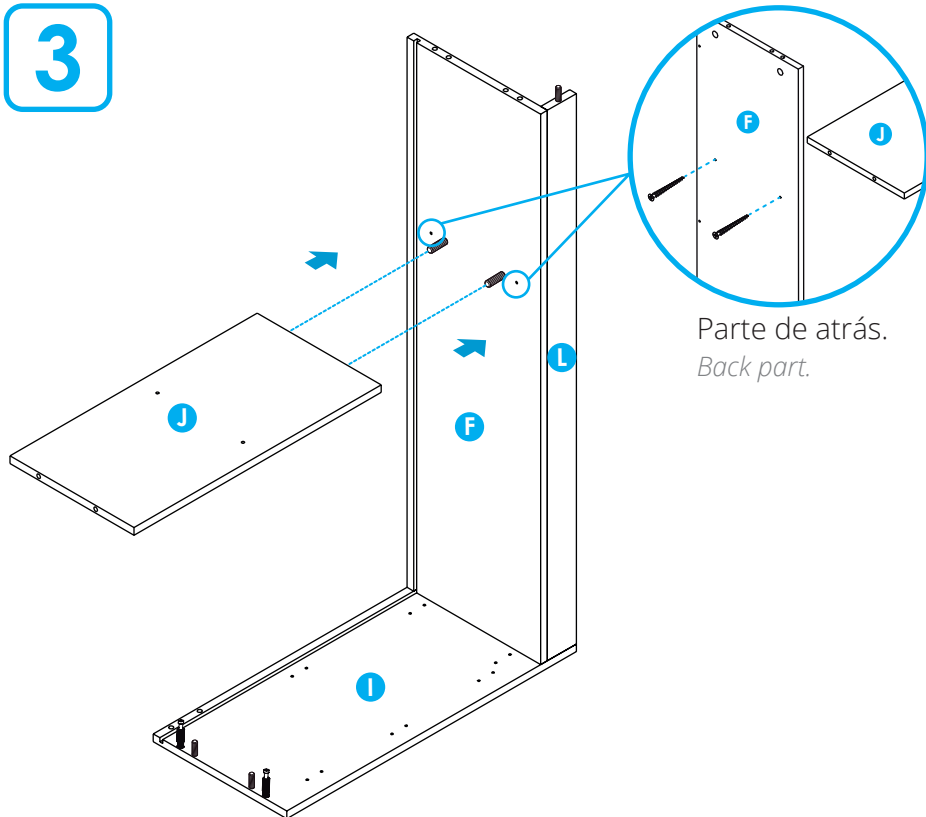

1

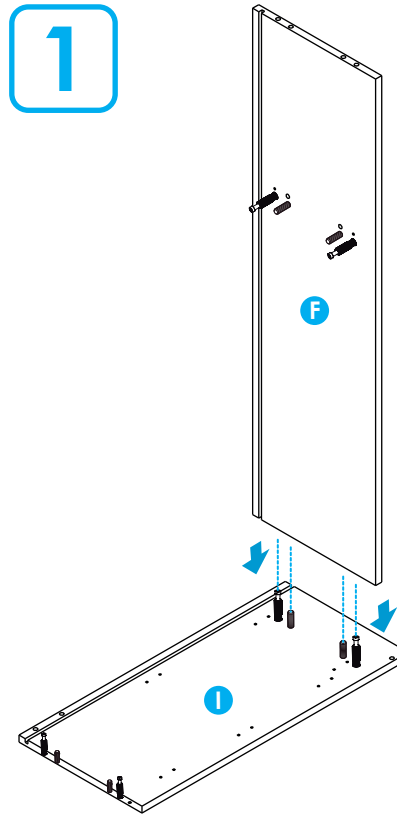

2

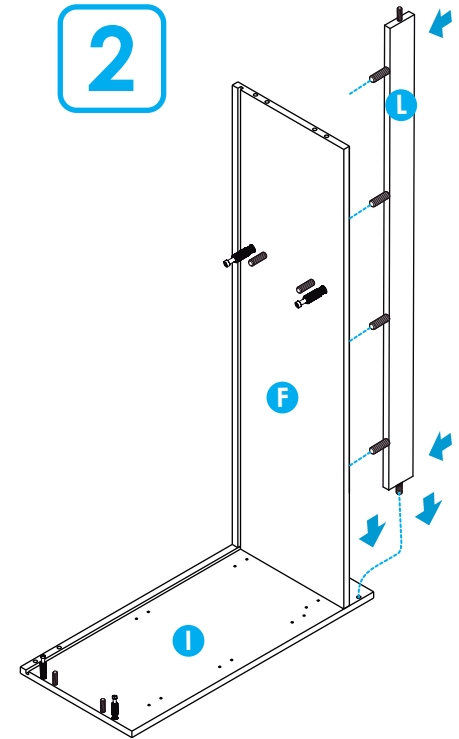

4

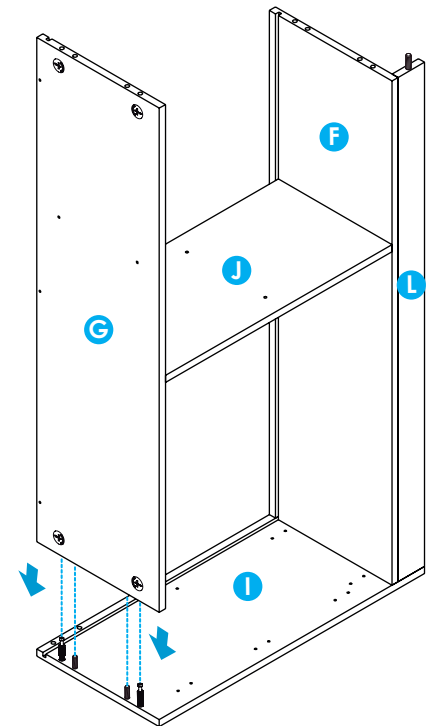

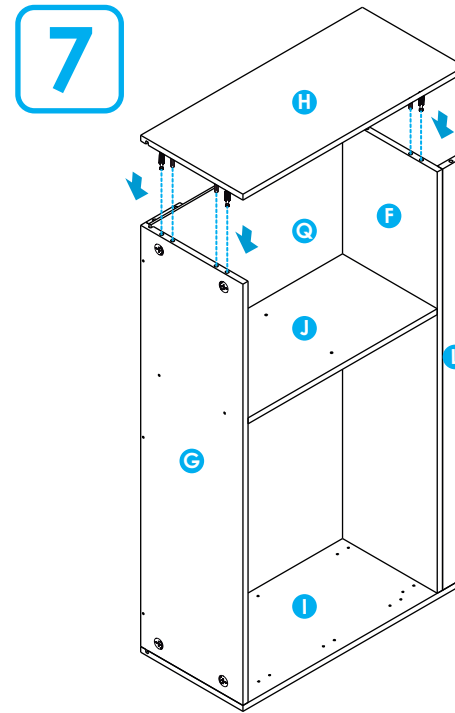
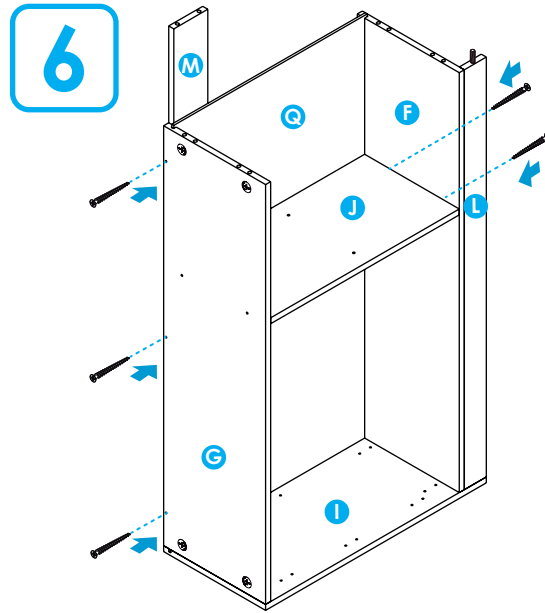
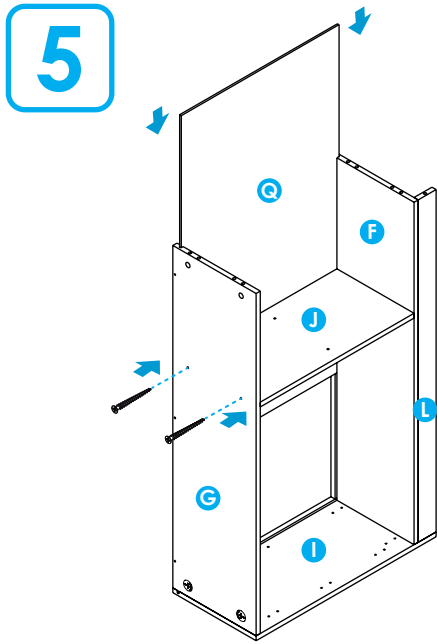

**8** Ensambaje de puertas.  
Door assembly.

**A.** Para instalar las puertas al mueble se ensamblará las bisagras.

**A.** To install the doors to the furniture, the hinges.

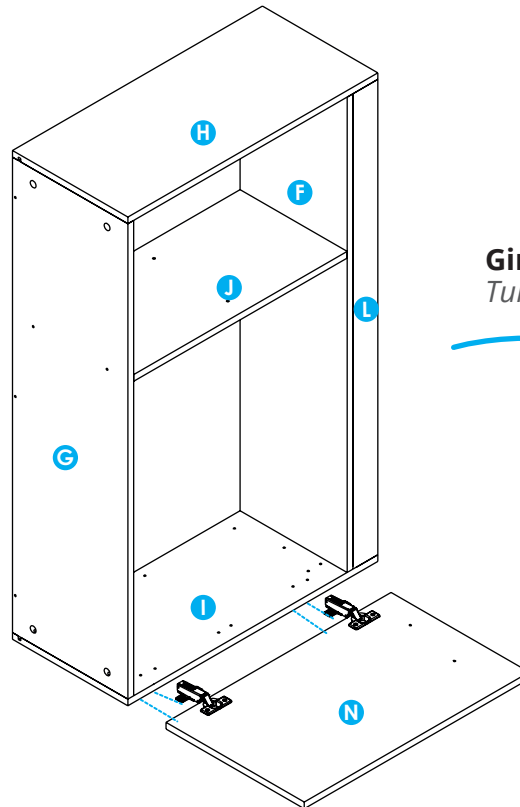

**Girar mueble**  
Turn cabinet

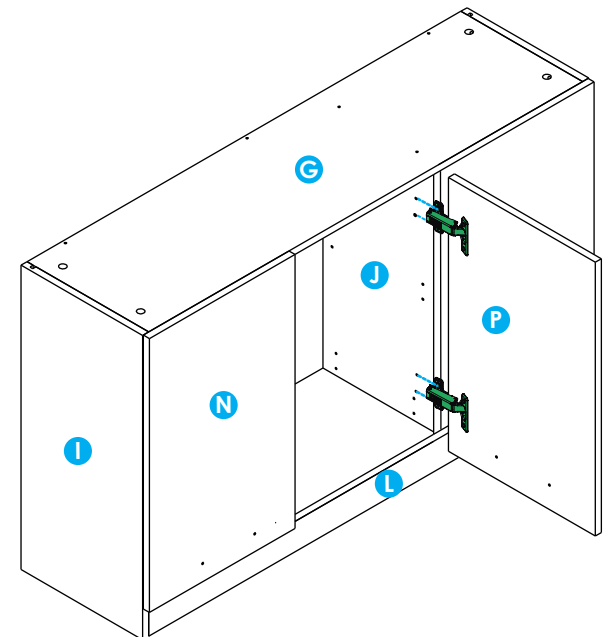



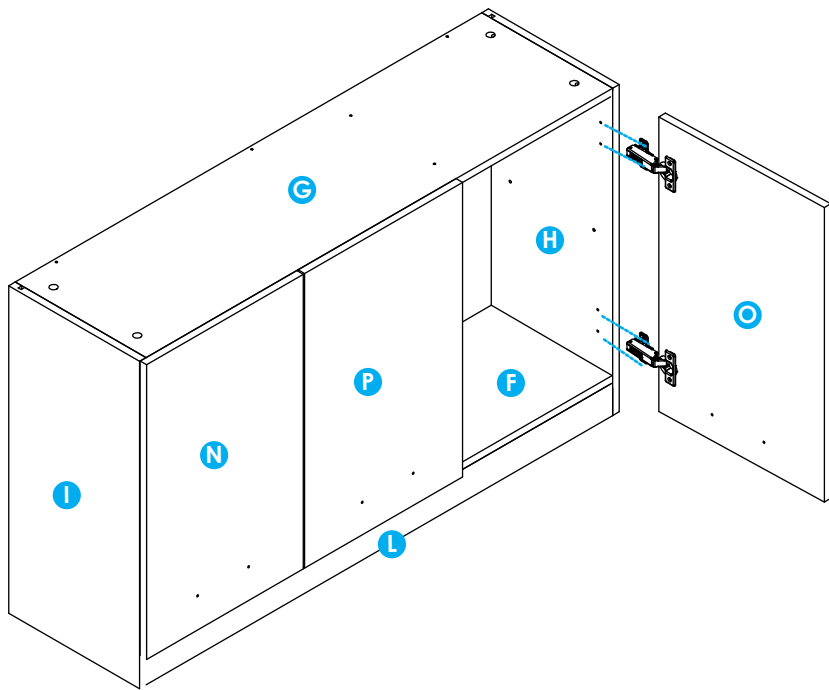

**C. Ajuste de profundidad:** le permite llevar las puertas hacia dentro o hacia afuera, aflojando el tornillo de la bisagra, como lo muestra el detalle.

*C. Depth adjustment: allows you to move the doors in or out, loosening the hinge screw as shown in detail.*

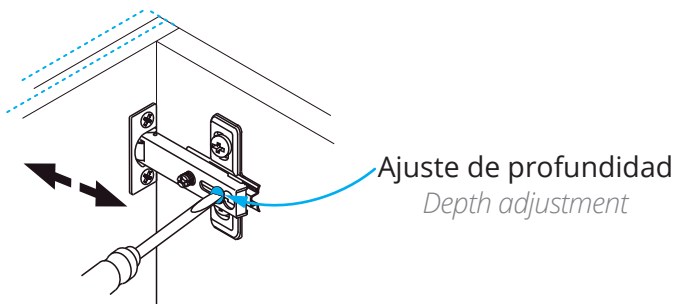

**B. Nivelar:** Para nivelar las puertas cuadrándolas al nivel deseado, afloje el tornillo de la bisagra, como lo muestra el detalle. Cuando esté en el lugar indicado, asegure los tornillos bisagra.

*B. Level: To level the doors, to meet the desired level, loosen the hinge screw, as shown in detail. When in the right place, secure the hinge screws.*

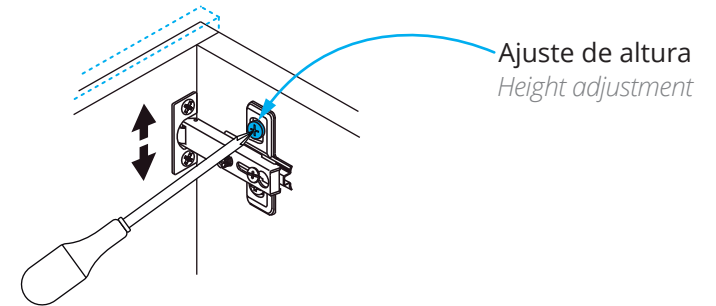

**D. Ajuste lateral:** le permite llevar las puertas hacia la derecha o la izquierda, nivelándola con los laterales aflojando o apretando el tornillo de la bisagra como lo muestra el detalle.

*D. Side adjustment: Allows you to move the doors to the right or left, leveling with the sides loosening or tightening the hinge screw as shown by the detail.*

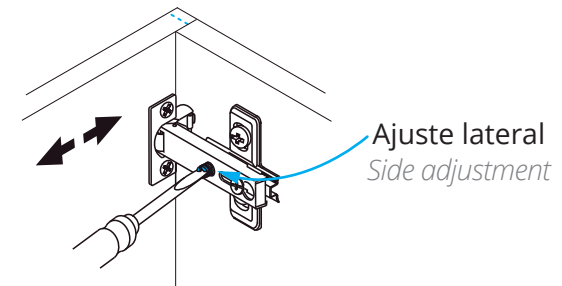

8

Ensamble de manijas.  
Handle assembly.

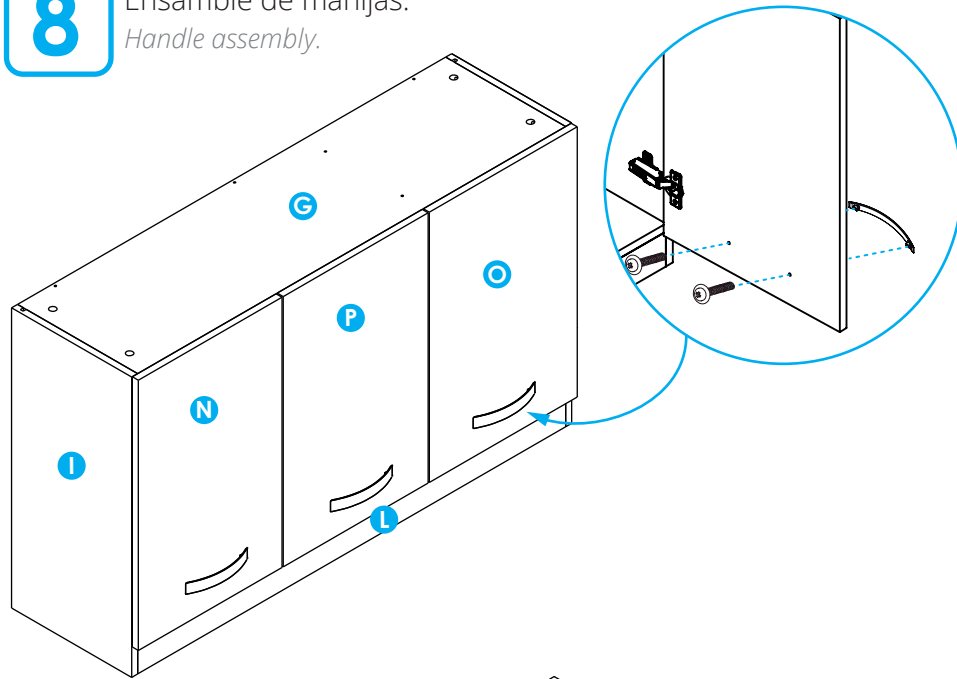

9

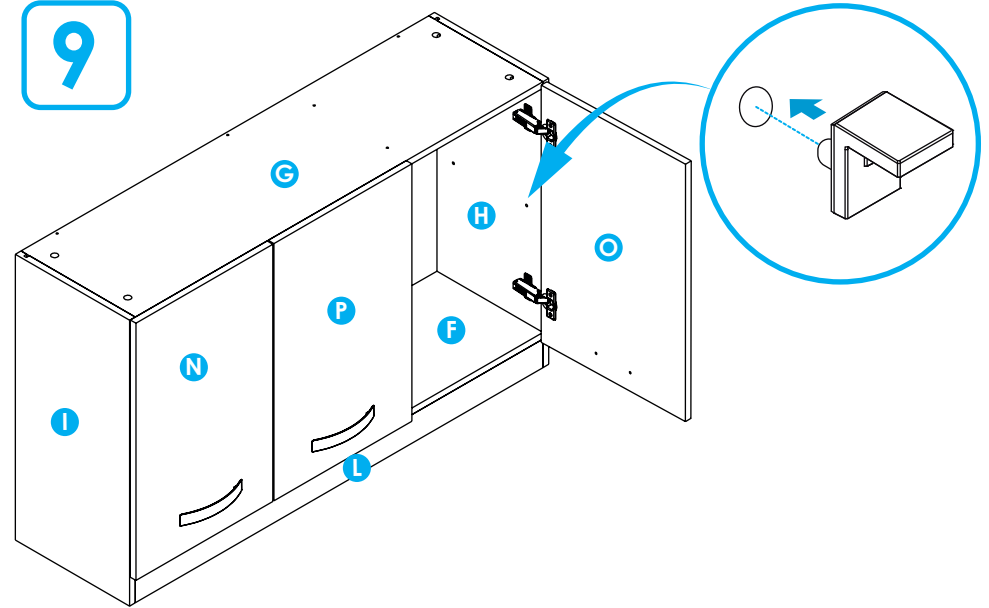

10

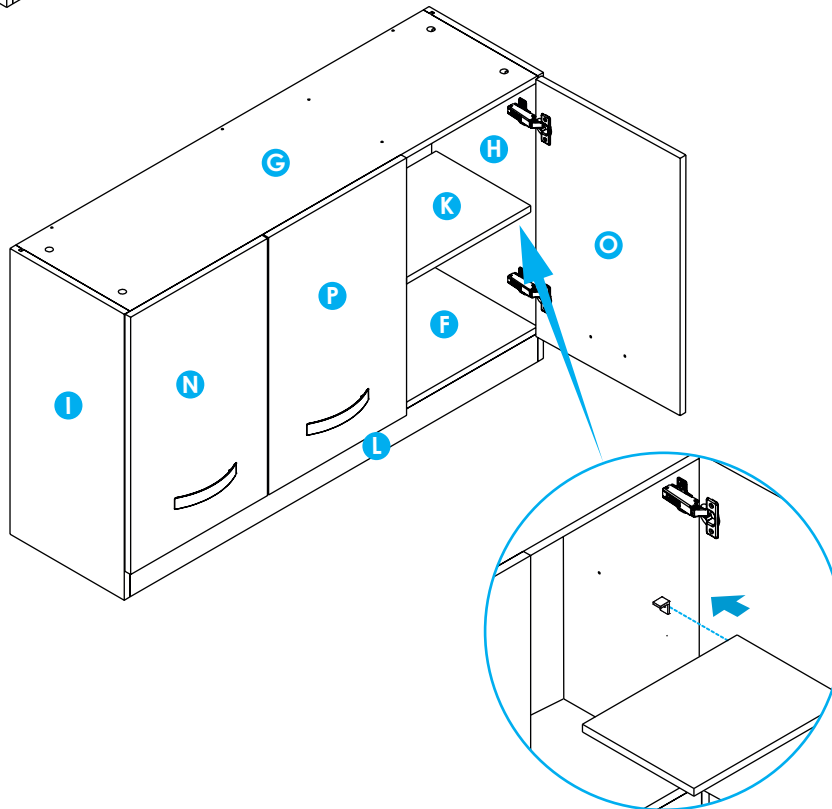

11

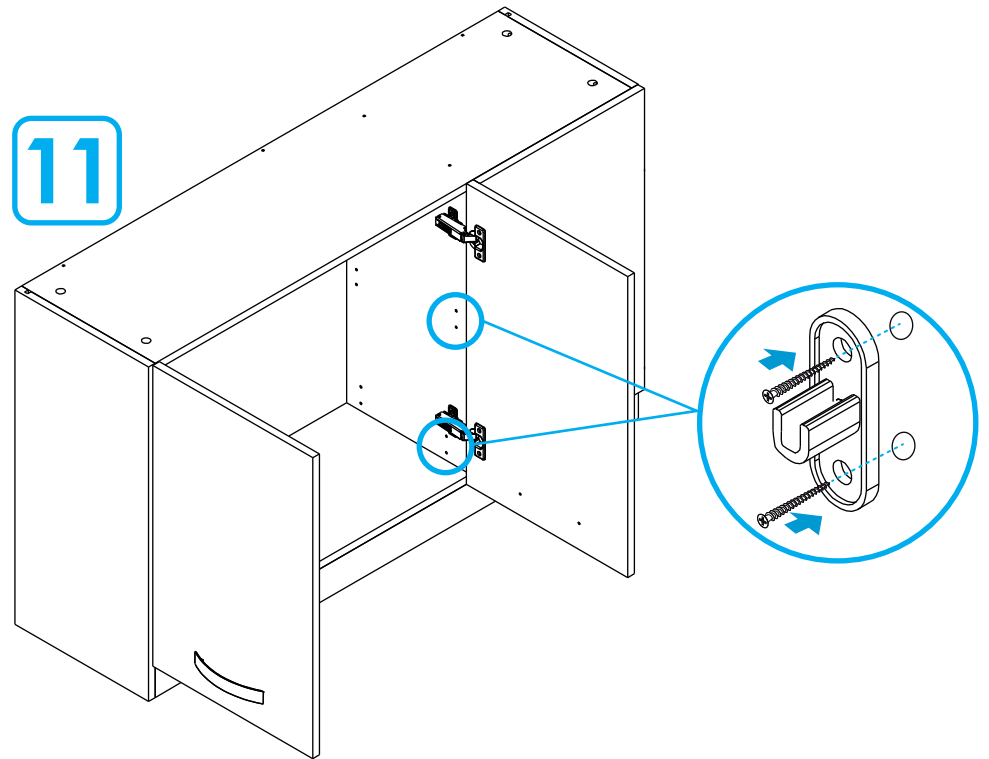

11

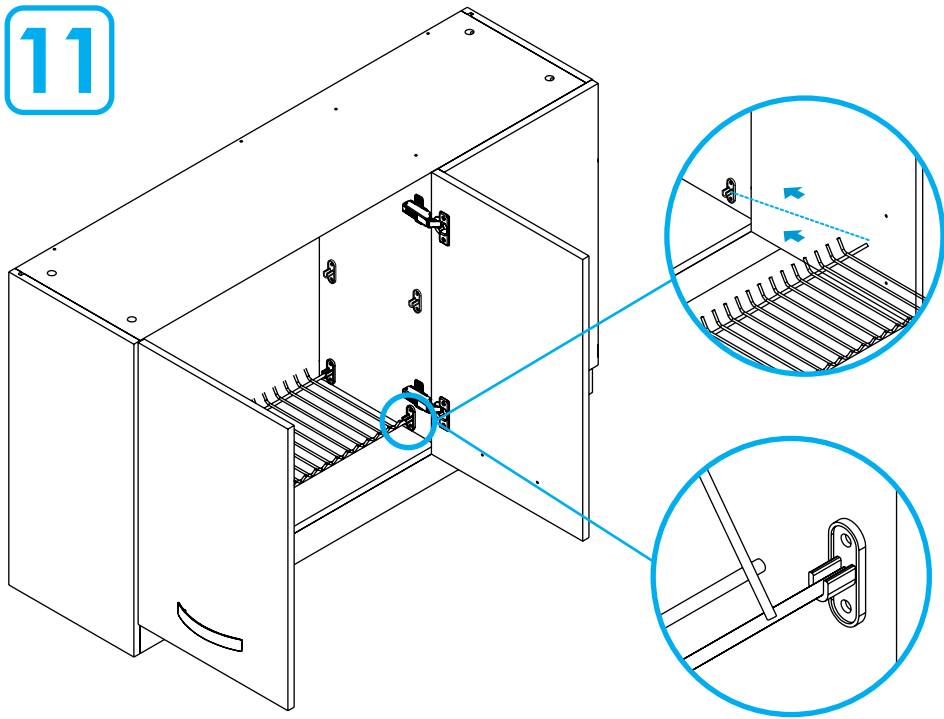

12

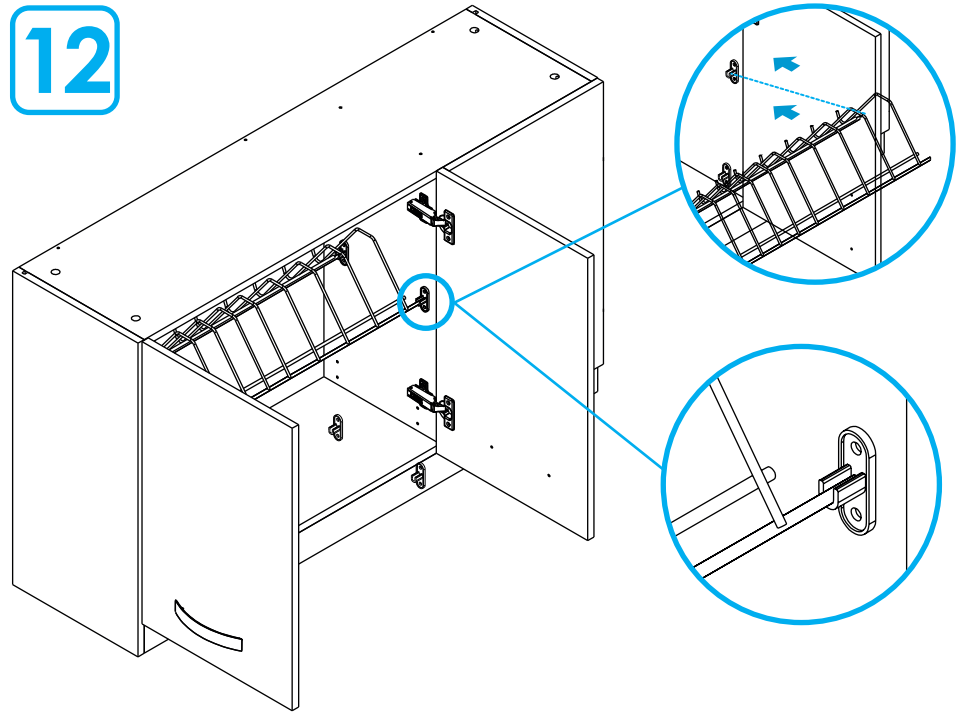

14

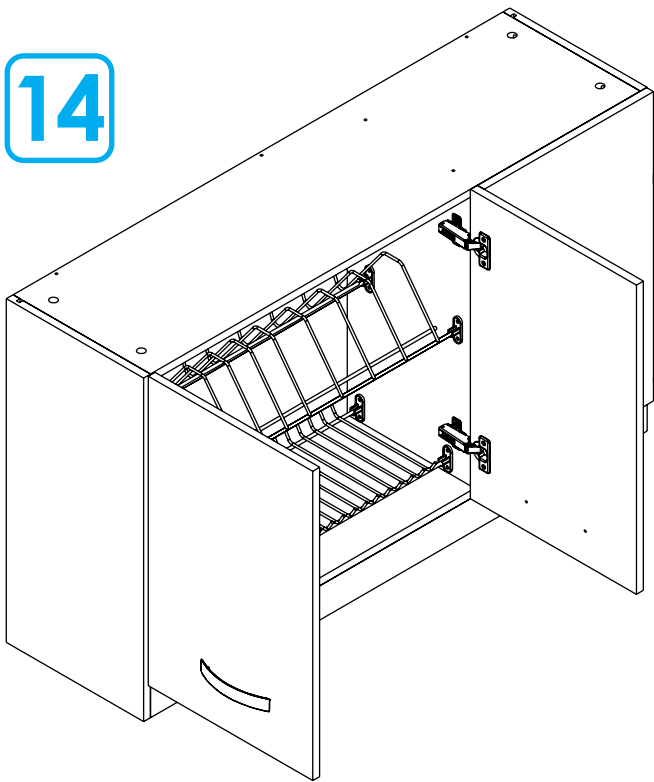

\* Mueble armado completamente  
Fully assembled cabinet

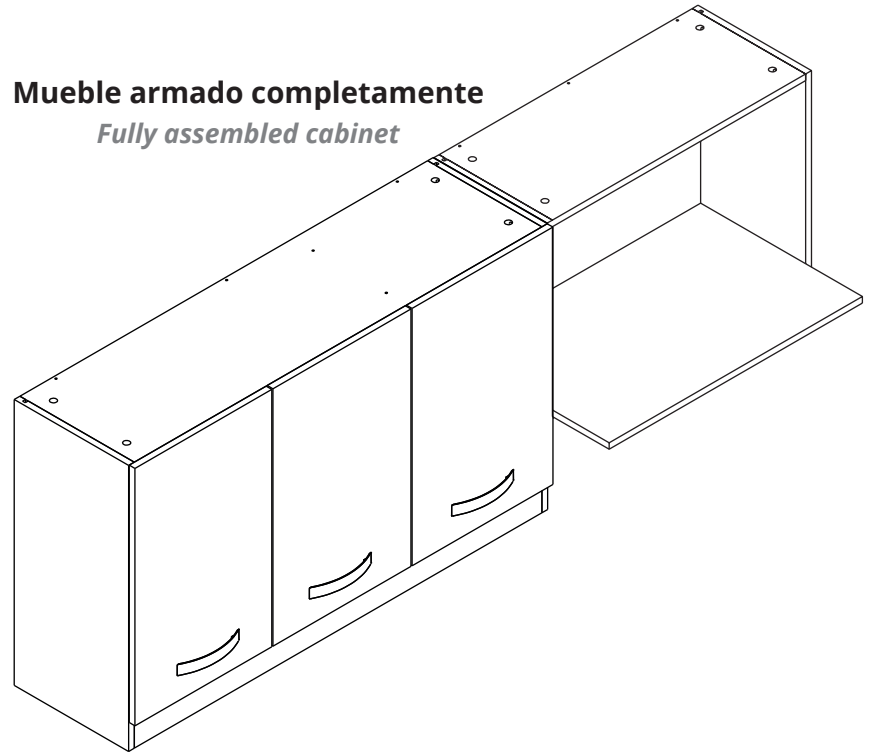

**11 Montaje del mueble a pared:** Para este paso necesitarás.  
**Wall-mounting cabinet:** For this step you will need.

**Herramientas**  
*Tools*



**Herrajes**  
*Fittings*



**Instalación anclaje con cuña**  
**Wall wedge installation**

**A** Identifique la posición correcta del anclaje con cuña, para que éste pueda ser instalado de manera adecuada en la pared.  
*Identify the correct position of the wall wedge, so that it can be properly installed on the wall.*

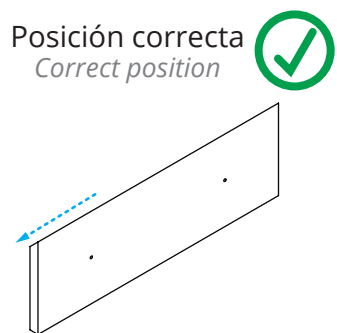
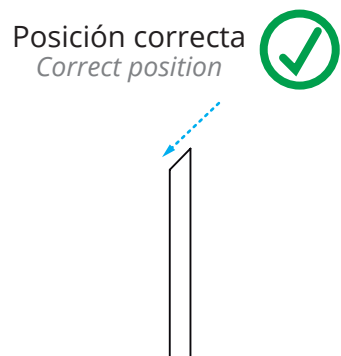

Posiciones incorrectas  
Wrong positions

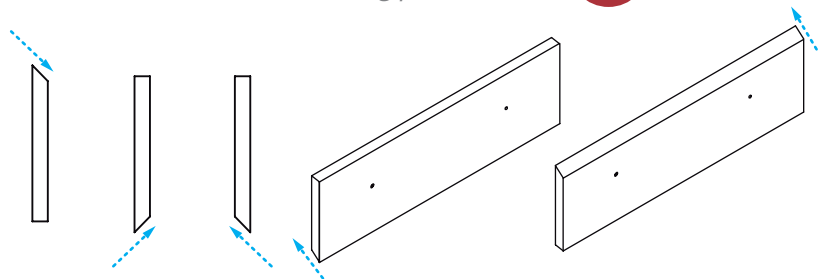

**B** Mida 1,90 m (medida sugerida) desde el piso hacia arriba, marque el punto final e instale allí los anclajes con cuña con la ayuda de una regla niveladora.

*Measure 74.8" (suggested measurement) from the floor up, mark the end point and install the wall wedge there using a leveling ruler.*

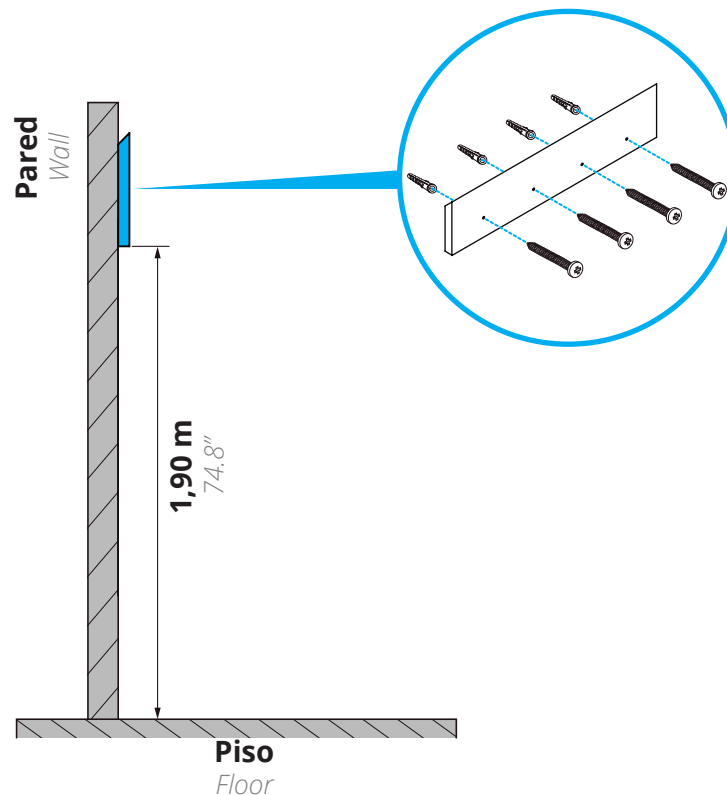

**IMPORTANTE:**

Tenga en cuenta que las paredes deben ser sólidas, de cemento / ladrillo. Si va a instalar el mueble sobre paredes de Drywall (paredes secas), debe utilizar chazos y tornillo de expansión metálico especial para drywall.

**IMPORTANT:**

*note that the walls must be solid, cement / brick. In case of drywall installation, change the ramplug for a drywall metallic Spring Toggle.*



**Para fijar el mueble:** Perfore la pared a la altura de los agujeros ubicados en las piezas **S** y **T** del mueble con ayuda de una broca para pared (tungsteno) 3/8", luego introduzca los chazos plásticos y fije las piezas **S** y **T** a la pared con la ayuda de los tornillos chazos; para finalizar descargue los muebles como se muestra en la siguiente imagen.

*To secure the cabinet: Drill the wall at the height of the holes located in the pieces **S** and **T** of the cabinet using a 3/8 "wall drill (tungsten), then insert the plastic shafts and fix the pieces **S** and **T** to the wall with the help of the chazos screws; Finally, download the furniture as shown in the following image.*

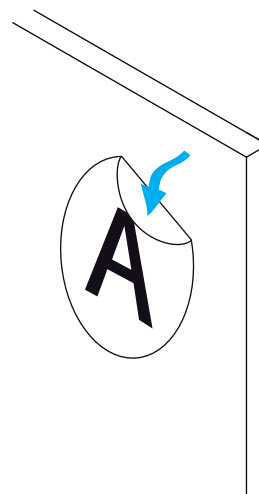
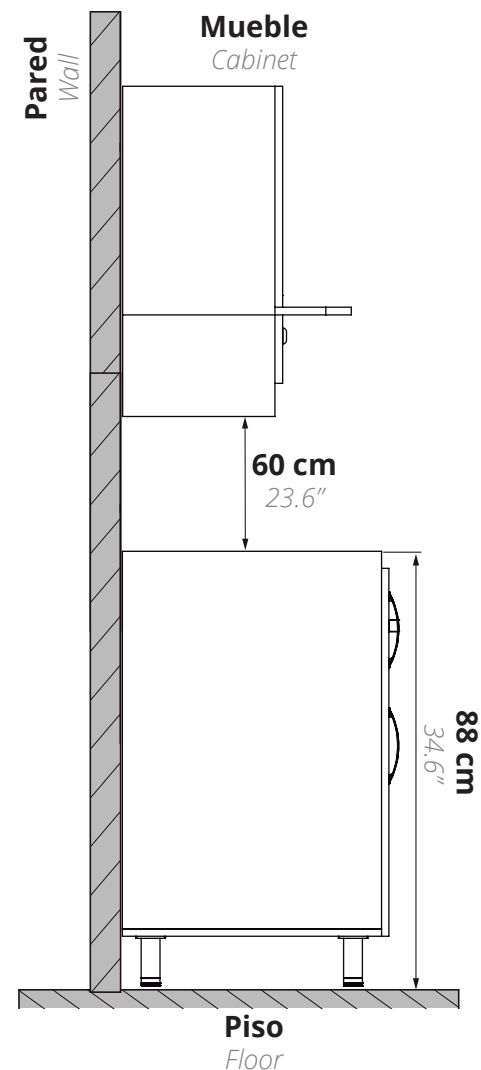
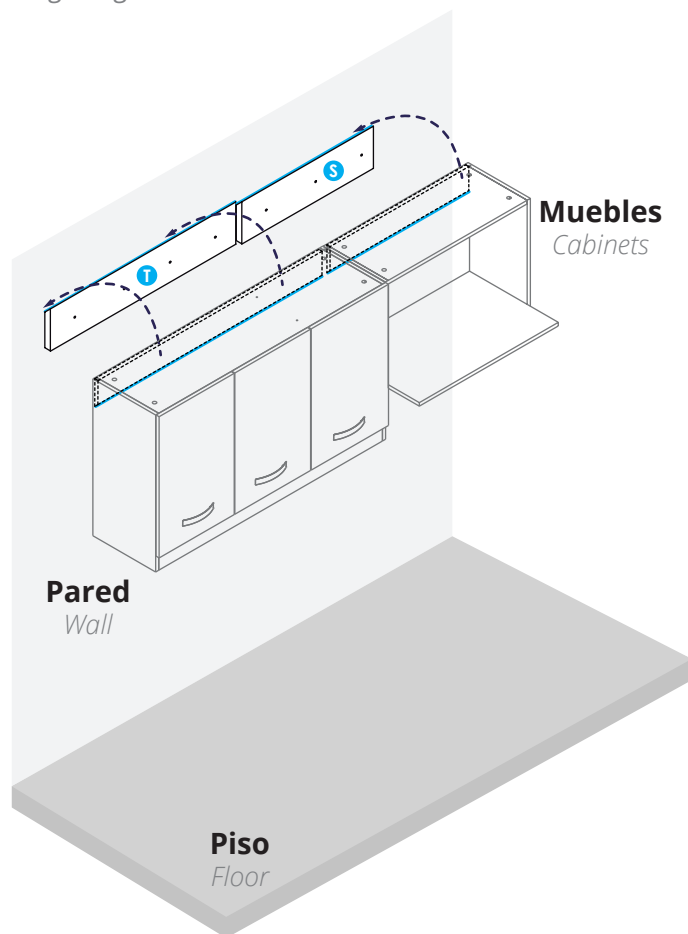

**Al terminar de armar desprenda los adhesivos (en caso de que queden residuos de pegante, limpie la superficie con alcohol).**

*When you finish assembling, remove the adhesives (in case there is glue residue, clean the surface with alcohol).*

## 4. Cuidados y mantenimiento

*Care and maintenance*

### Cuidados y mantenimiento para los muebles

- Para limpiar el mueble use un trapo seco o humedézcalo en agua y detergente suave, elimine el exceso de agua.
- No pinte ni barnice el mueble.
- No exponga el mueble a la intemperie.
- Evite arrastrarlo, puede ocasionar daños en la estructura.
- Por seguridad, evite que los menores jueguen con el mueble.
- No exponga el mueble a funciones diferentes para lo que fueron diseñados. Ejemplo: sentarse en el mueble.

### Care and maintenance for cabinet

- *To clean the cabinet, use a dry cloth or moisten it in water and mild detergent.*
- *Do not paint or varnish the furniture.*
- *Do not expose the furniture to the out side.*
- *Avoid dragging it, it can cause damage to the structure.*
- *For safety, avoid children playing with the furniture.*
- *Do not expose the furniture to different functions for which they were not designed. Example: sit on the furniture.*

**si necesita ayuda comuníquese con su asesor comercial firplak tel: 4441771 (ext: 108). tel: 4441771 (ext: 131)**

*if you need help, contact your **business advisor firplak** tel: 4441771 (ext: 131)*



[www.firplak.com](http://www.firplak.com)

Sede principal: Calle 29 N° 41-15 (Itagüí - Antioquia), Teléfono: (574) 444 17 71